

NEW

GAS/LIGHT OIL

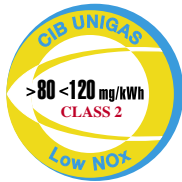

E165A E205A...SR **tecnopress** SERIES

Like all the other dual fuels models, this series perfectly combines the mechanical devices and systems typical of gas burners with the ones of light oil burners. In this way this series can burn the two flues separately.

This is possible because these burners are equipped with an independent electric motor for the activation of the oil pump. As a consequence during gas firing, the oil pump motor does not operate and remains off.

They are equipped with a high performance combustion head designed to achieve the maximum efficiency when they work on natural gas; combustion head is also equipped with a by-passing nozzle which, using a pressure regulator, can reach a turndown ratio 1:3.

The control panel is printed with a mimic diagram fitted with neon lamps to indicate the different stages of the burner operation. The burner is provided by an UV photocell to detect the flame during operation.

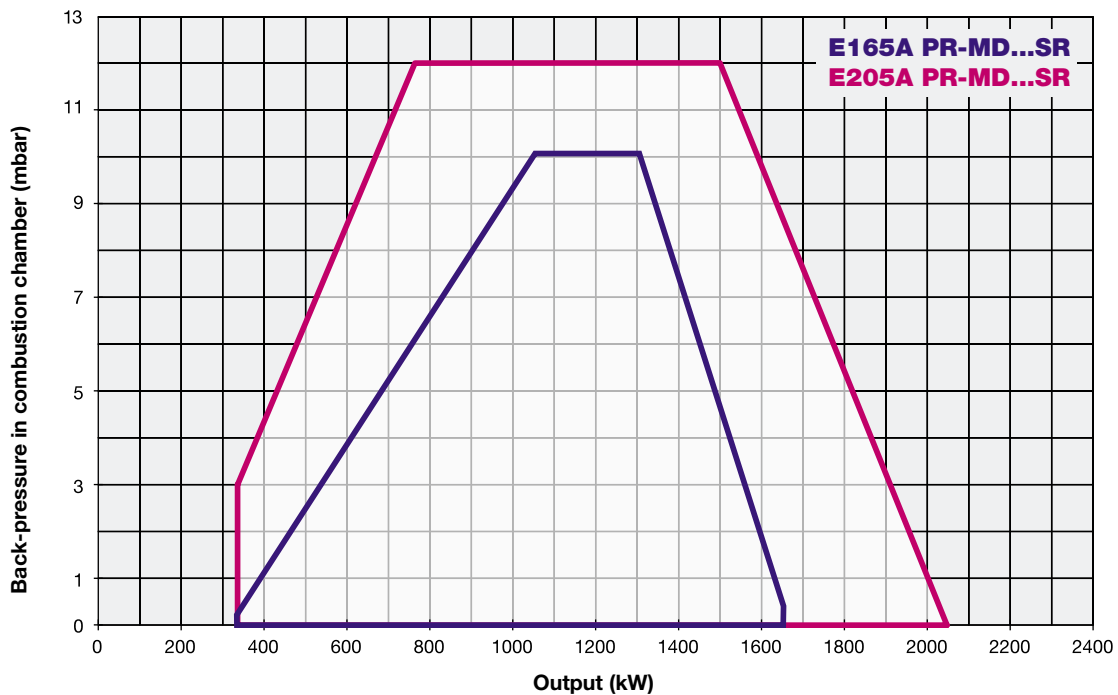

TECHNICAL DETAILS

Type	Model	Power kW		Electric power supply	Fan motor kW	Pump motor kW	Gas connections	Noise level dBA
		min.	max.					
E165A	MG.xx.SR.xx.A.1.xx	320	1.650	230/400 V 3N ac	2,2	0,55	1"½ - 2" - DN65 - DN80	< 75
E205A	MG.xx.SR.xx.A.1.xx	340	2.050	230/400 V 3N ac	3,0	0,55	1"½ - 2" - DN65 - DN80	< 75

For the configuration of the gas train, see page 101.

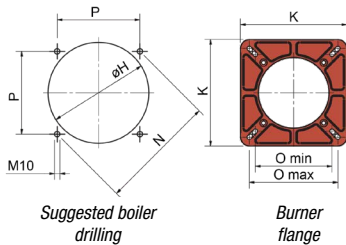
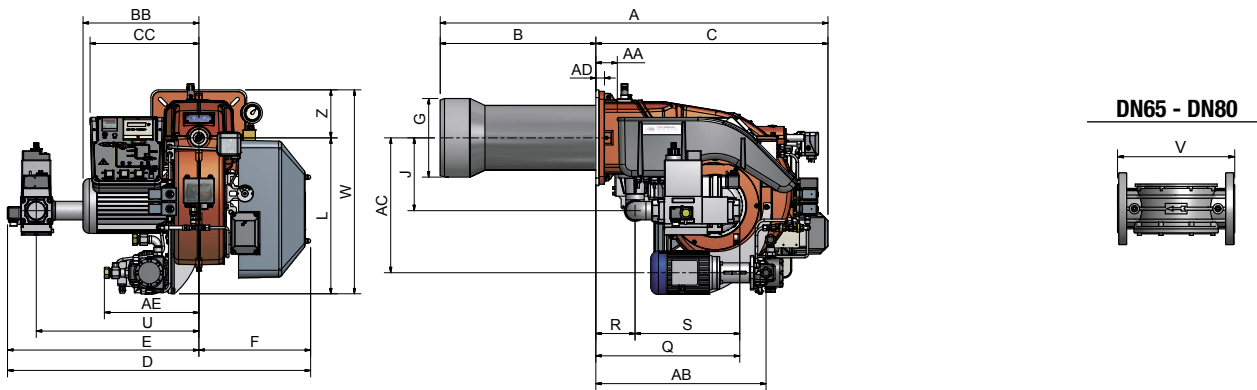

Type	Packaging dimensions (mm)			
	l	p	h	kg
E165A	1730	1280	1020	160
E205A	1730	1280	1020	160

Approximate values

Type	Model	Overall dimensions (mm)																										
		A	AA	AB	B	BB	C	CC	D	E	F	G	H	J	K	L	M	N	O		P	Q	R	S	U	V	W	Z
		min. max.																										
E165A	MG.xx.SR.xx.A.1.40	1331	69	550	500	372	831	352	1050	716	362	234	264	233	300	503	M10	330	216	250	233	457	130	327	541	-	658	155
E165A	MG.xx.SR.xx.A.1.50	1331	69	550	500	372	831	352	985	651	362	234	264	233	300	503	M10	330	216	250	233	472	130	342	526	-	658	155
E165A	MG.xx.SR.xx.A.1.65	1331	69	550	500	372	831	352	1134	800	362	234	264	233	300	503	M10	330	216	250	233	562	130	432	593	292	658	155
E165A	MG.xx.SR.xx.A.1.80	1331	69	550	500	372	831	352	1108	774	362	234	264	233	300	503	M10	330	216	250	233	562	130	432	565	310	658	155
E205A	MG.xx.SR.xx.A.1.40	1334	69	550	503	403	831	352	1050	716	362	254	270	235	300	503	M10	330	216	250	233	457	130	327	541	-	658	155
E205A	MG.xx.SR.xx.A.1.50	1334	69	550	503	403	831	352	985	651	362	254	270	235	300	503	M10	330	216	250	233	472	130	342	526	-	658	155
E205A	MG.xx.SR.xx.A.1.65	1334	69	550	503	403	831	352	1134	800	362	254	270	235	300	503	M10	330	216	250	233	562	130	432	593	292	658	155
E205A	MG.xx.SR.xx.A.1.80	1334	69	550	503	403	831	352	1108	774	362	254	270	235	300	503	M10	330	216	250	233	558	130	428	565	310	658	155

Approximate values

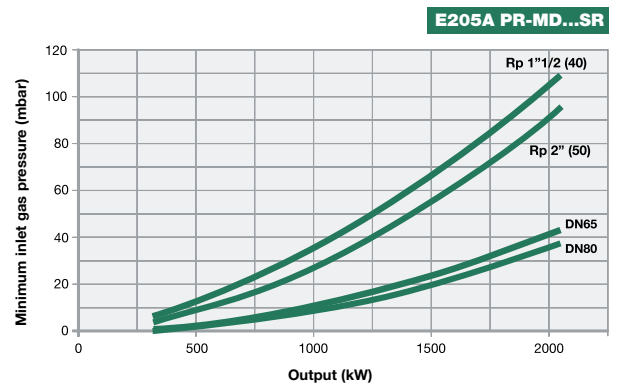
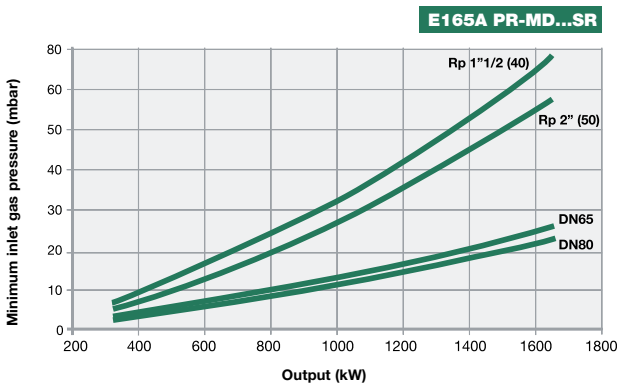
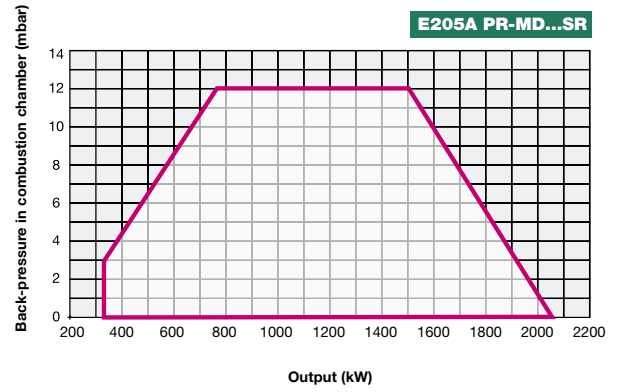
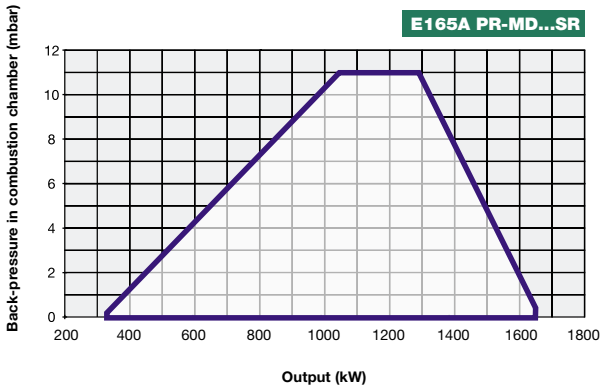

Attention: the graph shows the value of the gas output (kW) against the corresponding pressure without the combustion chamber back pressure. To know the minimum gas pressure at gas train, in order to get the gas output, it is necessary to add the boiler back pressure to the value read on the curve.