

# RN510 RN515 RN520 RN525 **cinquecento** SERIES

**MECHANICAL ATOMIZATION**  
with viscosity up to 400 cSt at 50°C (50°E at 50°C)

## TECHNICAL DETAILS

Type	Model	Output kW		Auxiliary electrical power supply	Motor electrical power supply	Fan motor kW	Pump motor kW	Resistor kW	Noise level dBA
		min.	max.						
<b>RN510</b>	x-.xx.x.xx.A	1.314	3.953	230 V 1N AC 50 Hz	400 V 3 AC 50 Hz	7,5	1,1	24	81,7
<b>RN515</b>	x-.xx.x.xx.A	1.628	4.884	230 V 1N AC 50 Hz	400 V 3 AC 50 Hz	11,0	1,5	12 + 18	82,3
<b>RN520</b>	x-.xx.x.xx.A	2.326	6.977	230 V 1N AC 50 Hz	400 V 3 AC 50 Hz	15,0	2,2	18 + 24	83,2
<b>RN525</b>	x-.xx.x.xx.A	2.000	8.000	230 V 1N AC 50 Hz	400 V 3 AC 50 Hz	18,5	2,2	24 + 24	84,9

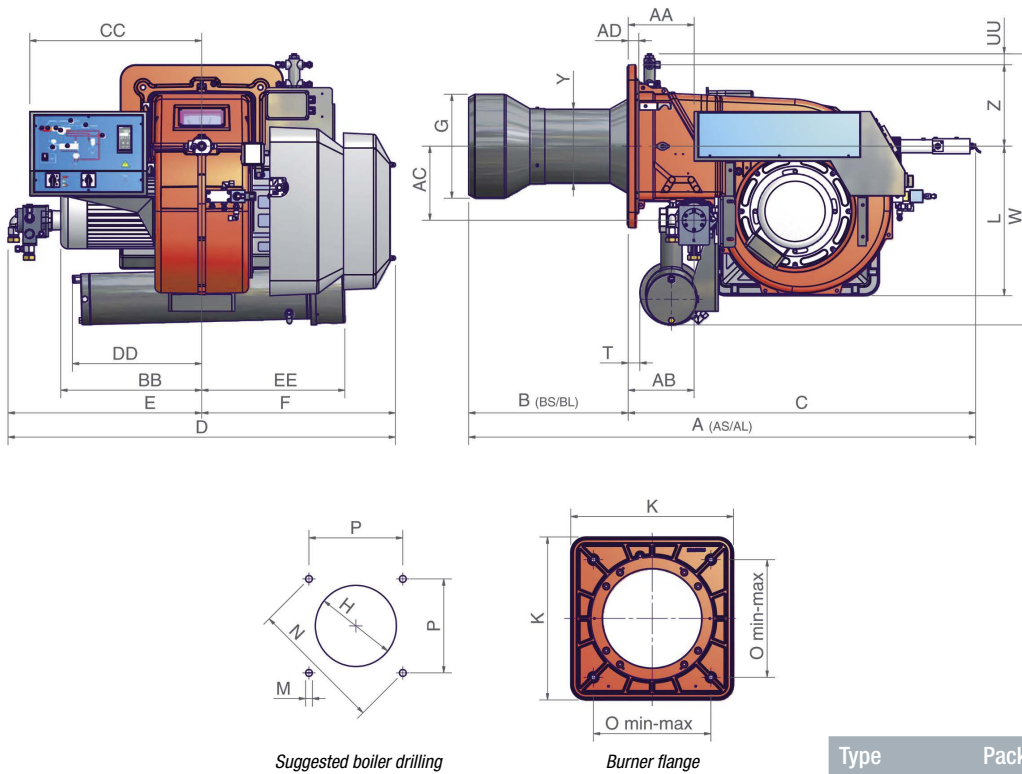

Type	Packaging dimensions (mm)			
	l	p	h	kg
<b>RN510</b>	1.720	1.500	1.150	410
<b>RN515</b>	1.720	1.500	1.150	410
<b>RN520</b>	1.720	1.500	1.150	410
<b>RN525</b>	1.800	1.500	1.300	430

Approximate values

Type	Model	Overall dimensions** (mm)																												
		AA	AS	AL	AB	AC	AD	BB	BS	BL	C	CC	D	DD	E	EE	F	G	H	K	L	M	N	O	P	T	UU	W	Y	Z
<b>RN510</b>	x-.xx.x.xx.A	221	1502	1682	217	246	35	468	350	530	1152	571	1286	349	643	556	643	345	385	540	496	M14	552	390	390	37	36	897	328	270
<b>RN515</b>	x-.xx.x.xx.A	145	1502	1682	217	246	35	508	350	530	1152	598	1286	-	643	-	643	384	424	540	496	M14	552	390	390	37	36	802	328	270
<b>RN520</b>	x-.xx.x.xx.A	145	1502	1682	207	250	35	508	350	530	1152	598	1286	-	643	-	643	422	472	540	496	M14	552	390	390	37	36	802	328	270
<b>RN525</b>	x-.xx.x.xx.A	145	1502	1682	197	275	35	650	350	530	1152	598	1286	-	643	-	643	434	484	540	496	M14	552	390	390	37	78	844	328	270

Approximate values