

01	RENAMED CONNECTORS "AUX3" & "AUX4"	22/07/20	U. PINTON
REV.	MODIFICA	DATA	FIRME



Impianto
TIPI/TYPES CxxxA(X) / ExxxA(X) / HR75A
MODELLO/MODEL xG-.PR(MD).S.xx.A.1.xx
 Descrizione
WITH LME73.xxx + CIRCUIT 6100574 + 6100566
(AND MODULATOR RWF55.x / RWF50.2x / 600V / KM3) + POMIN + POMAX

Ordine	
Commessa	Data Controllato 22/07/2020
Esecutore U. PINTON	Controllato M. MASCHIO

Data	23/09/2016	PREC.	FOGLIO
Revisione	01	/	1
Dis. N.	05 - 1140	SEQUE	TOTALE
		2	14

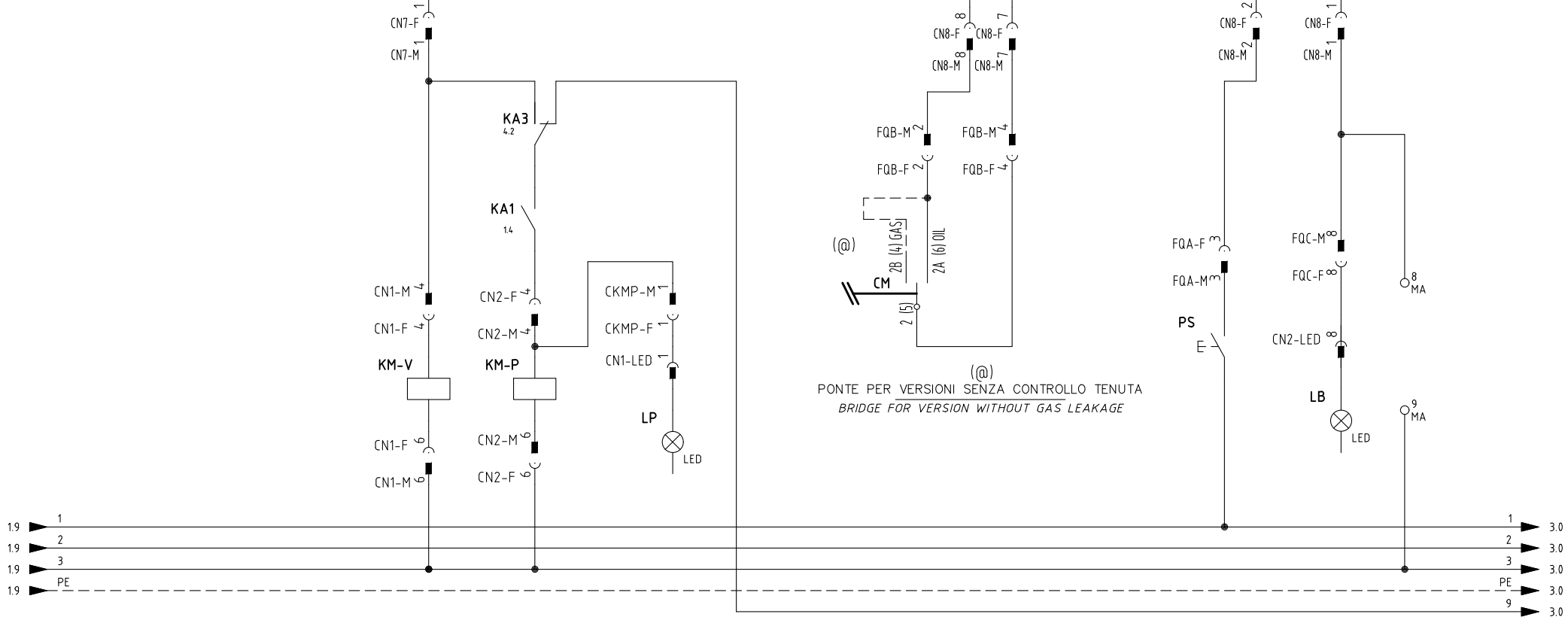
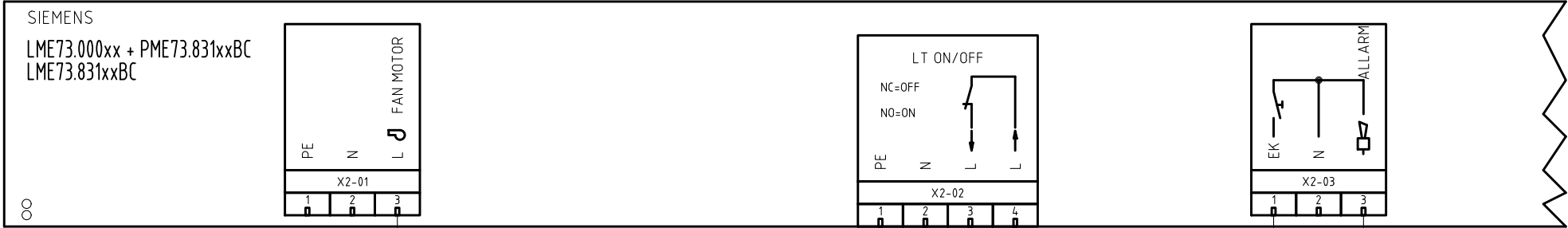

(@)
 PONTE PER VERSIONI SENZA CONTROLLO TENUTA
 BRIDGE FOR VERSION WITHOUT GAS LEAKAGE

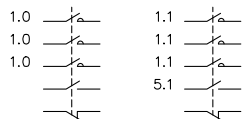

Data	23/09/2016	PREC.	FOGLIO
Revisione	01	1	2
Dis. N.	05 - 1140	SEGUE	TOTALE
		3	14

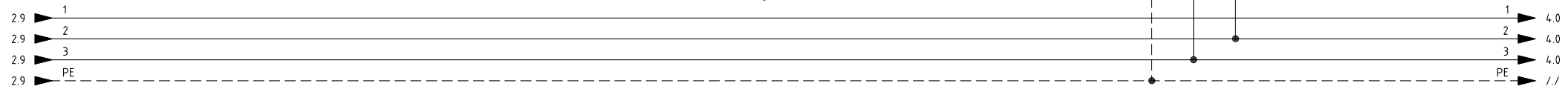
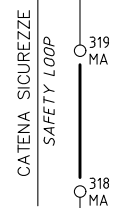
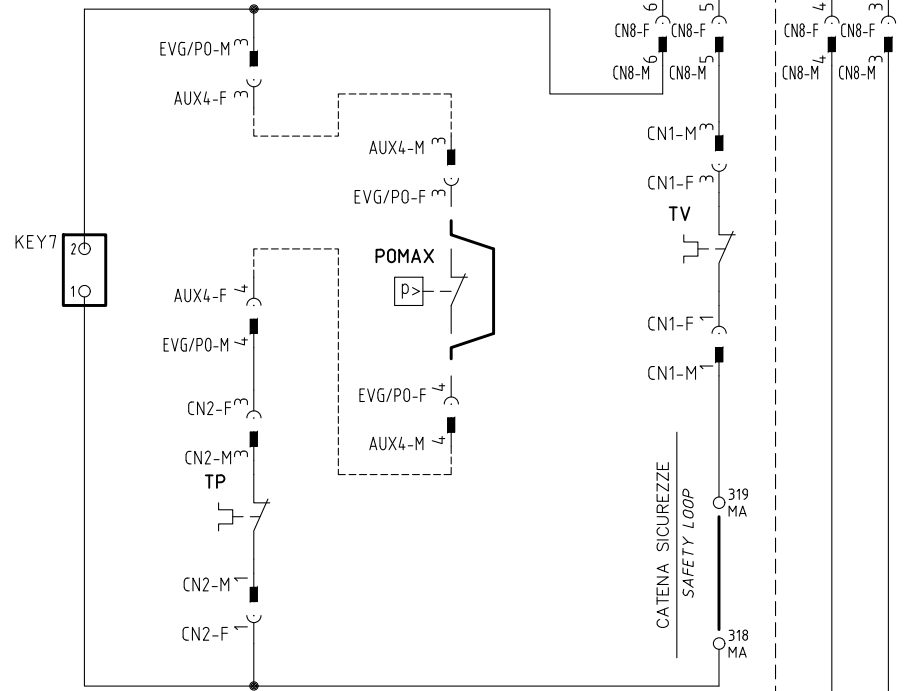
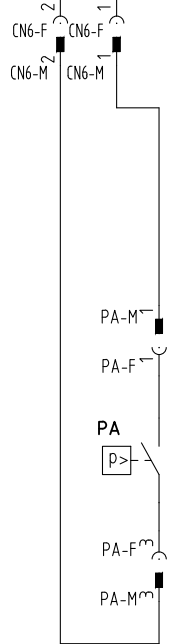
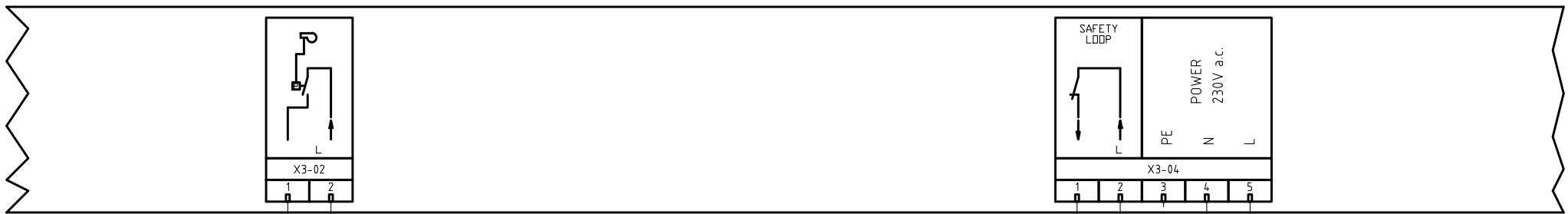

Data	23/09/2016	PREC.	FOGLIO
Revisione	01	2	3
Dis. N.	05 - 1140	SEGUE	TOTALE
		4	14

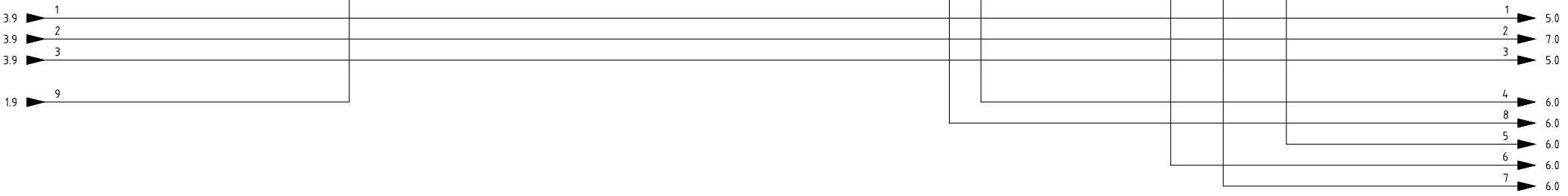
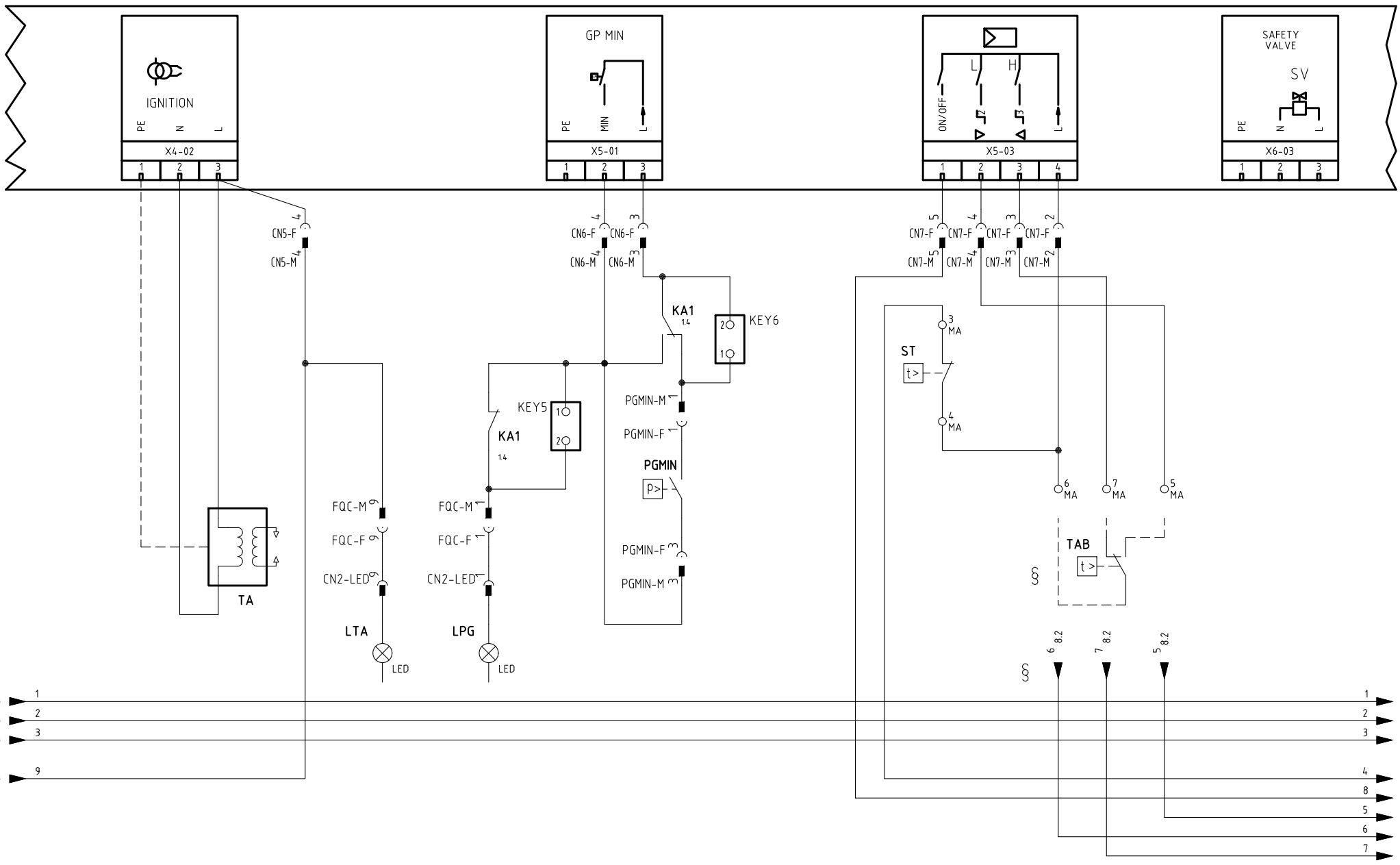

§

VERSIONE (PR) / VERSIONE (MD) CON RWF.. / 600V / KM3
 (PR) VERSION / (MD) VERSION WITH RWF. / 600V / KM3

Data	23/09/2016	PREC.	FOGLIO
Revisione	01	3	4
Dis. N.	05 - 1140	SEGUE	TOTALE
		5	14

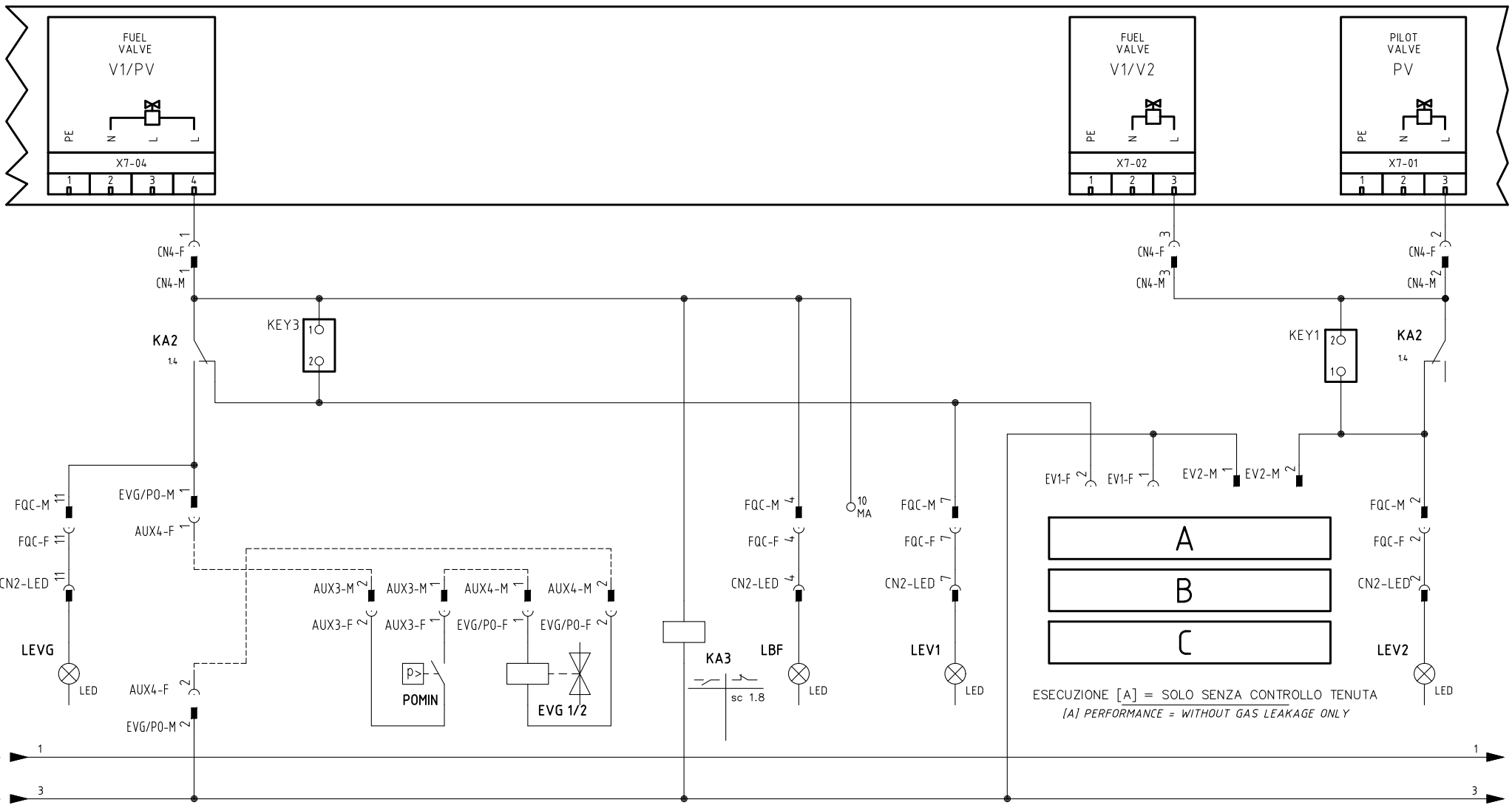

A
B
C

ESECUZIONE [A] = SOLO SENZA CONTROLLO TENUTA
[A] PERFORMANCE = WITHOUT GAS LEAKAGE ONLY

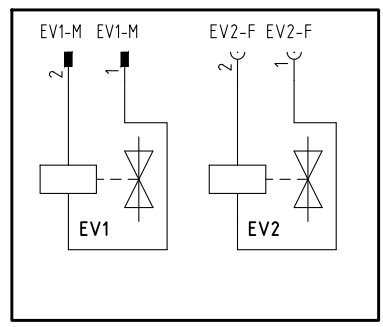
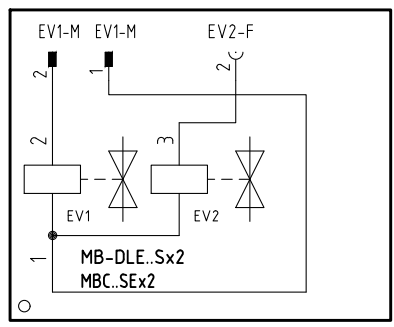
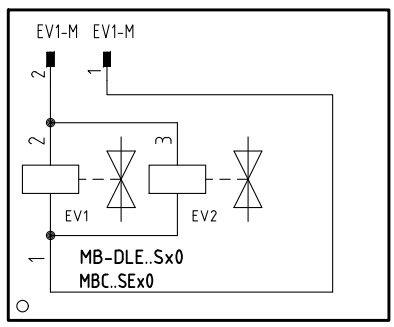

Data	23/09/2016	PREC.	FOGLIO
Revisione	01	4	5
Dis. N.	05 - 1140	SEGUE	TOTALE
		6	14

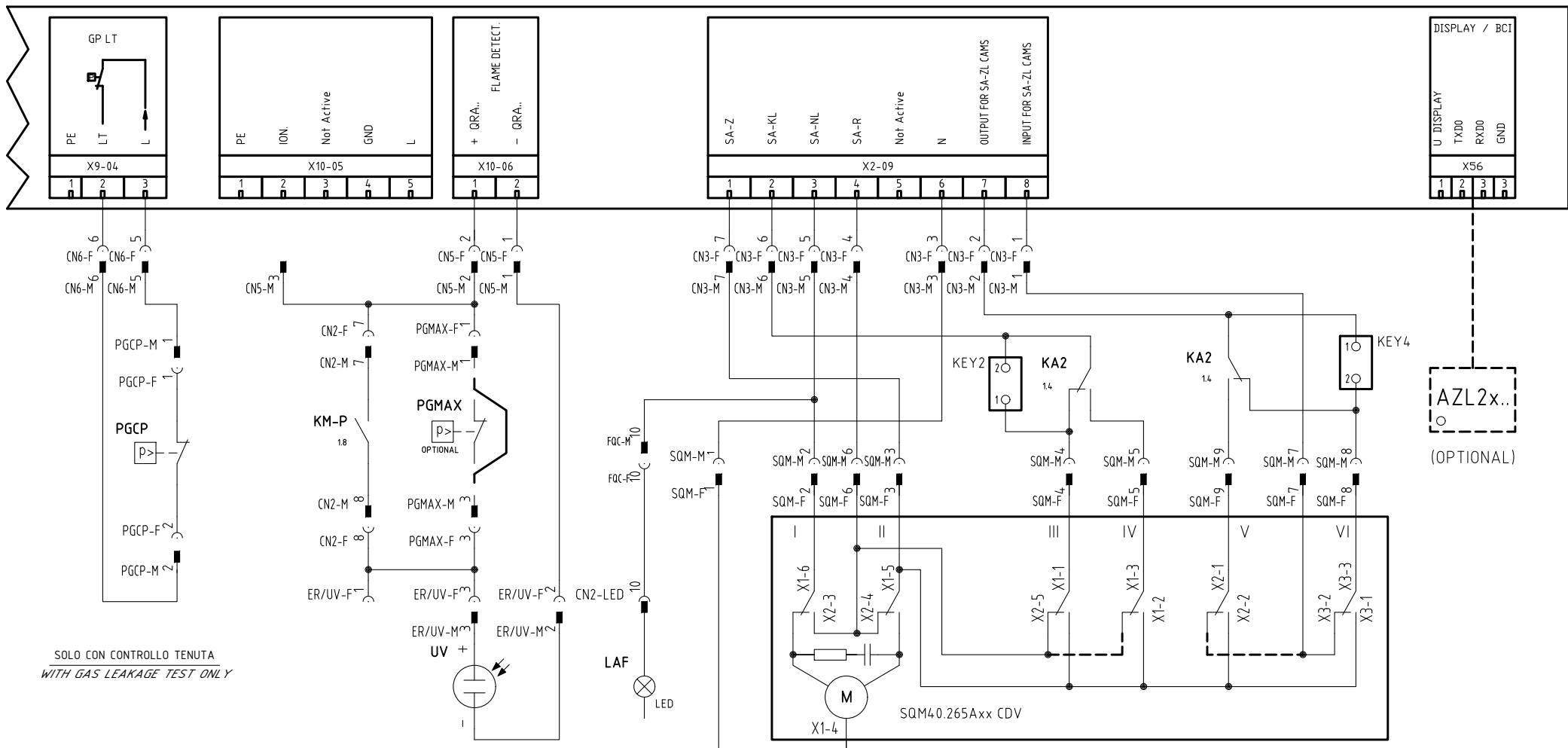

SOLO CON CONTROLLO TENUTA
WITH GAS LEAKAGE TEST ONLY

SERVOCOMANDO SERRANDA ARIA
AIR DAMPER ACTUATOR
SQM40.265Axx CDV

- I ALTA FIAMMA
HIGH FLAME
- II SOSTA
STAND-BY
- III BASSA FIAMMA GAS
GAS LOW FLAME
- IV BASSA FIAMMA GASOLIO
LIGHT OIL LOW FLAME
- V ACCENSIONE GASOLIO
LIGHT OIL IGNITION
- VI ACCENSIONE GAS
GAS IGNITION

Data	23/09/2016	PREC.	FOGLIO
Revisione	01	5	6
Dis. N.	05 - 1140	SEGUE	TOTALE
		7	14

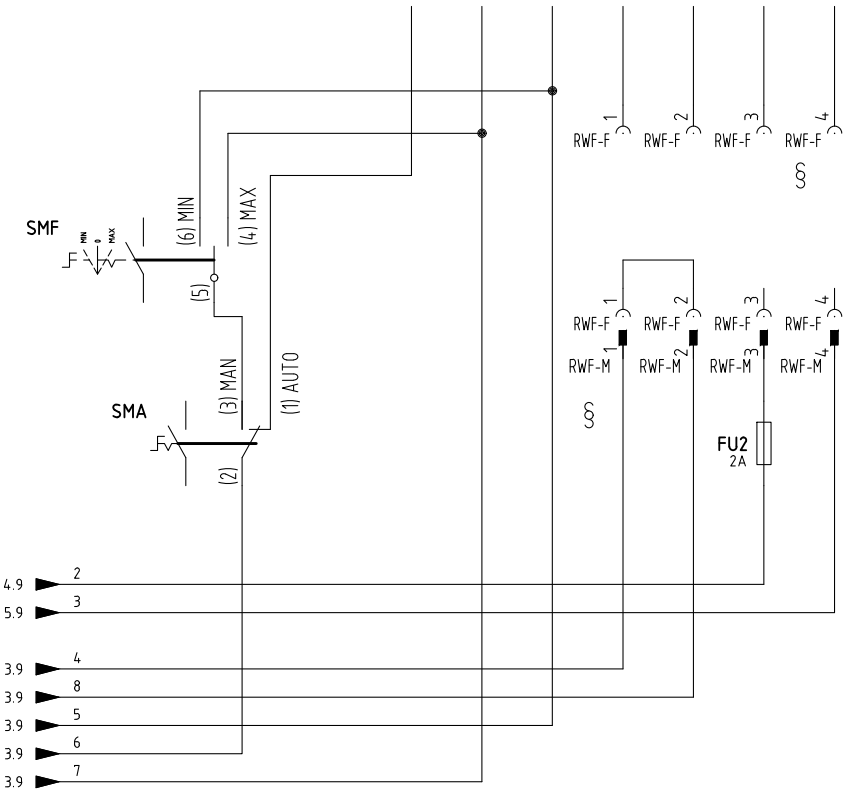
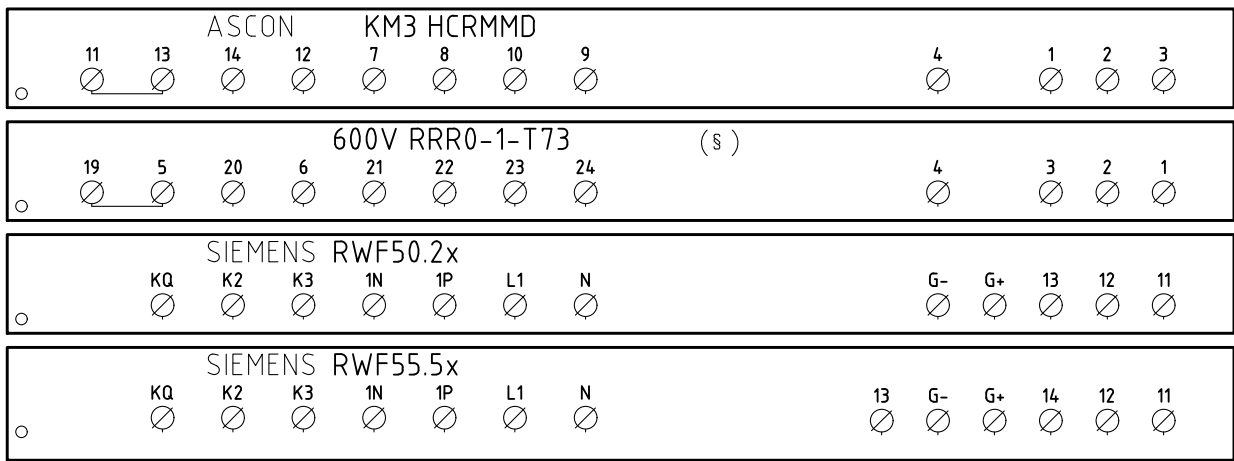

CONN. 7 PINS

- L1 (1) MARRONE BROWN
- N (2) BLU BLUE
- B5 (3) ROSSO RED
- T6 (4) NERO BLACK
- T7 (5) BIANCO WHITE
- T8 (6) ARANCIO ORANGE

CAVO 7x0,75mmq
CABLE 7x0,75mmq

(xx)
ATTENZIONE COLLEGAMENTO SONDE CON CONNETTORE 7 POLI
WARNING PROBE CONNECTION WITH 7 PINS CONNECTOR

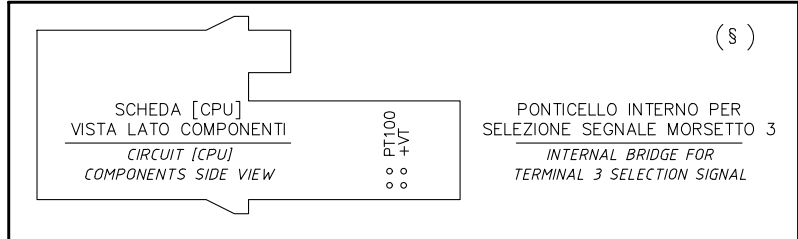

§
VERSIONE (PR) / VERSIONE (MD) CON RWF.. / 600V / KM3
(PR) VERSION / (MD) VERSION WITH RWF.. / 600V / KM3

Data	23/09/2016	PREC.	FOGLIO
Revisione	01	6	7
Dis. N.	05 - 1140	SEQUE	TOTALE
		8	14

(xx)
 ATTENZIONE COLLEGAMENTO SONDE CON CONNETTORE 7 POLI
 WARNING PROBE CONNECTION WITH 7 PINS CONNECTOR

KM3 HCRMMD

600V RRR0-1-T73

RWF55.5x

RWF50.2x

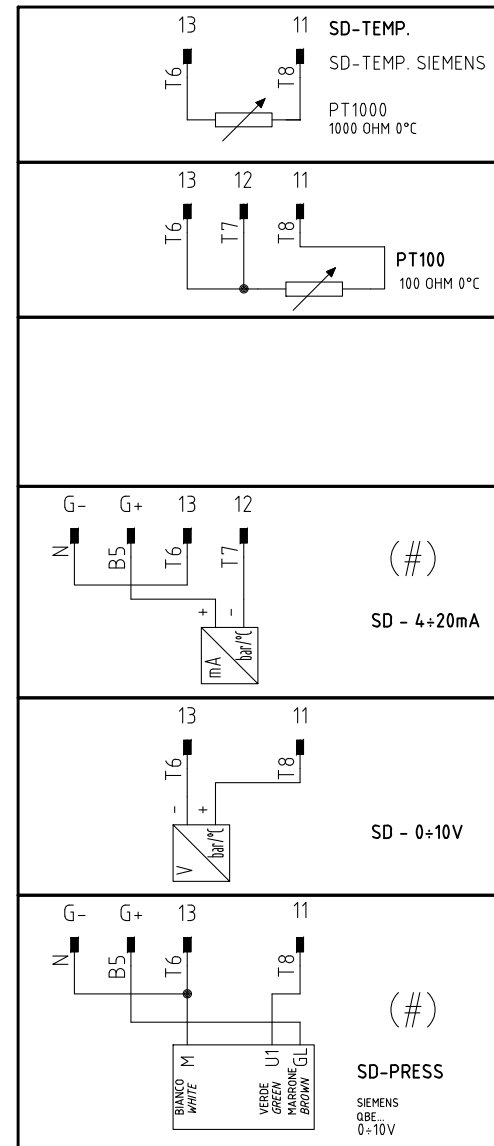
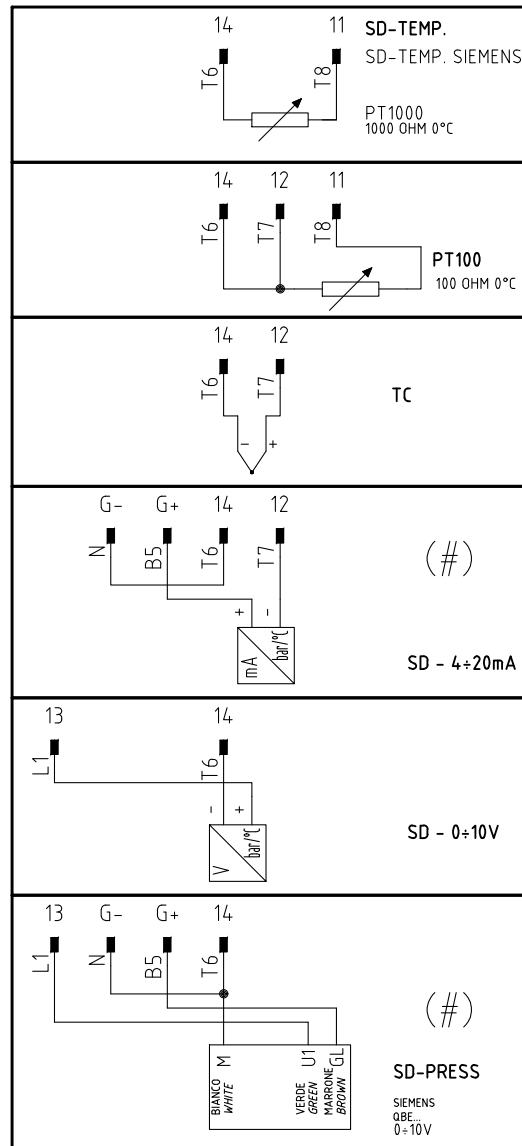
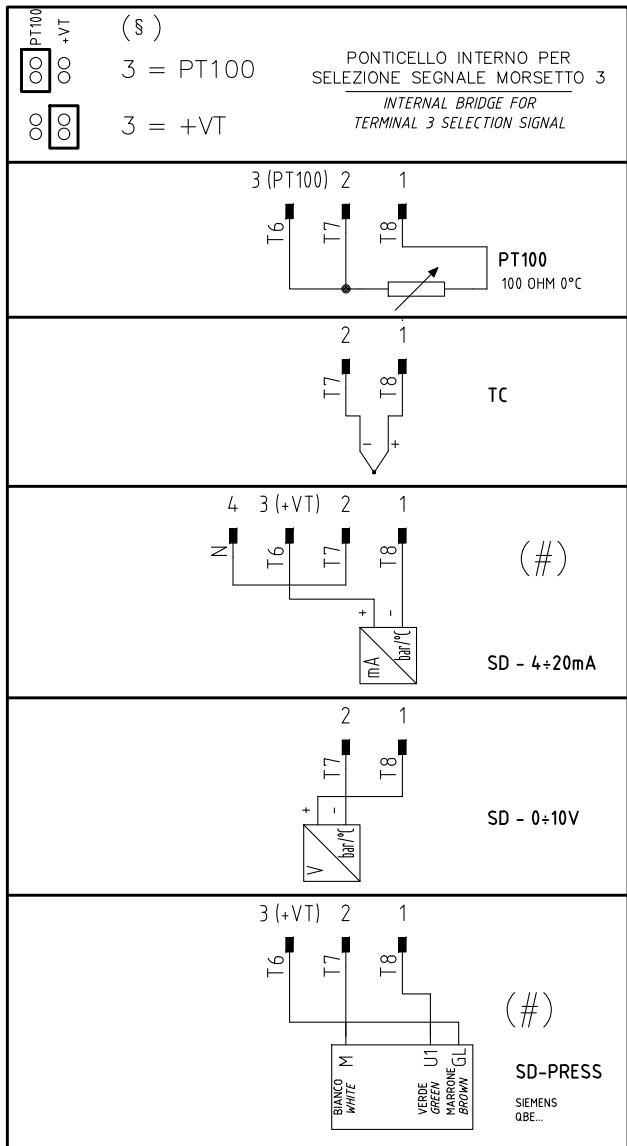
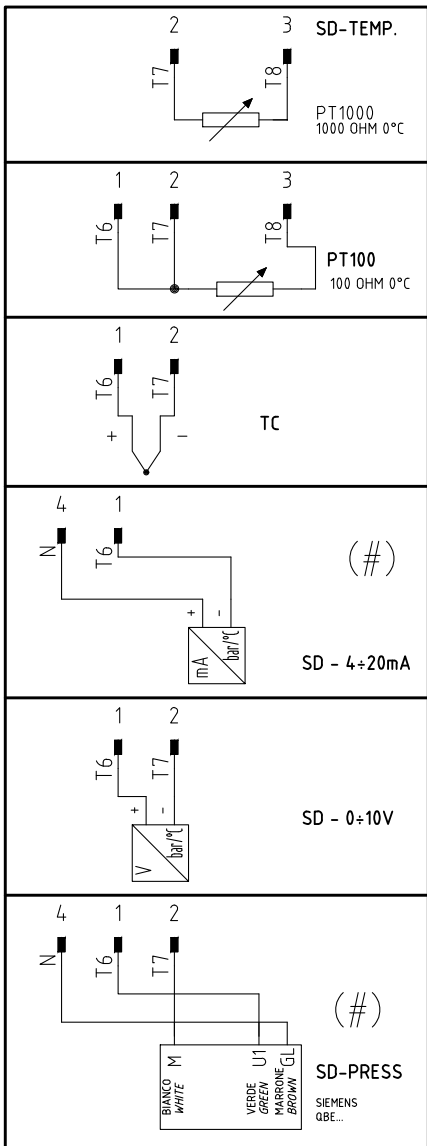

(#)
 COLLEGAMENTO SOLO PER
 TRASDUTTORI PASSIVI
 TRASDUCER PASSIVE
 CONNECTION ONLY

Data	23/09/2016	PREC.	FOGLIO
Revisione	01	7	8
Dis. N.	05 - 1140	SEGUE	TOTALE
		9	14

QG - MA
MORSETTIERA ALIMENTAZIONE BRUCIATORE
BURNER SUPPLY TERMINAL BOARD

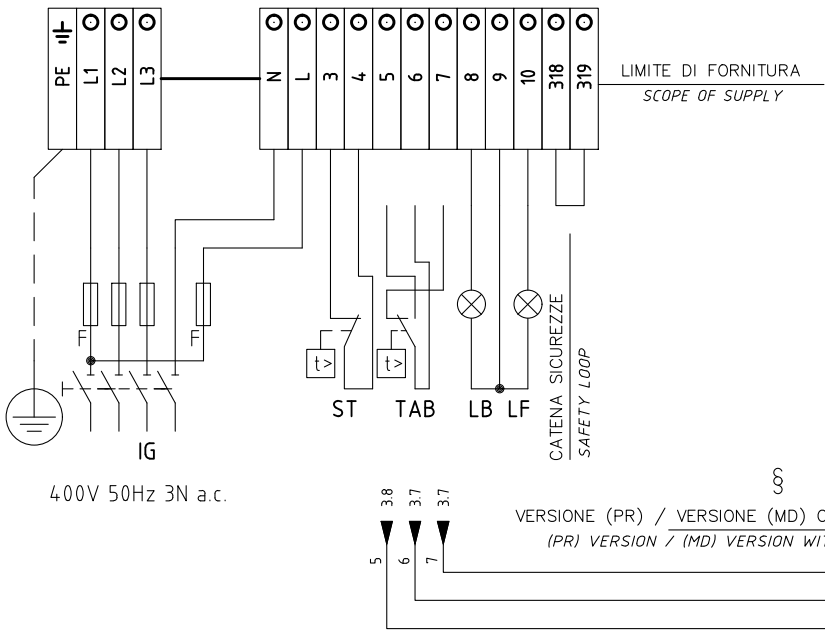

VERSIONE (PR) / VERSIONE (MD) CON RWF.. / 600V / KM3
 (PR) VERSION / (MD) VERSION WITH RWF.. / 600V / KM3

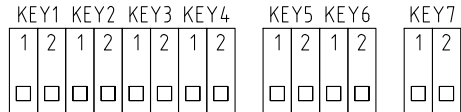
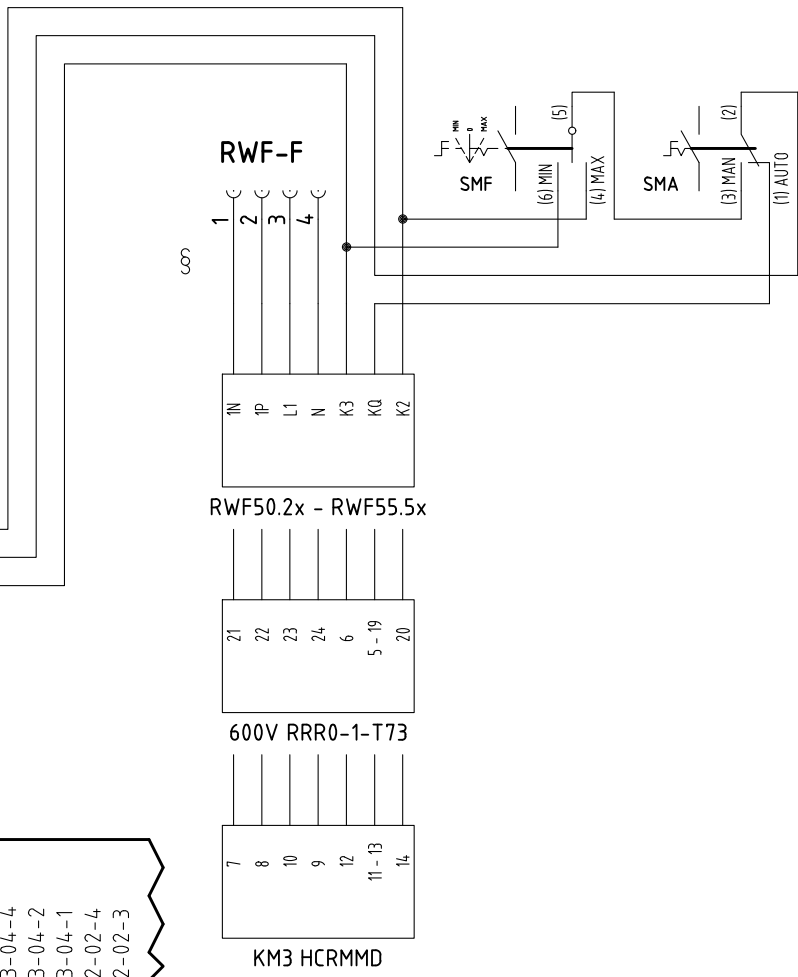
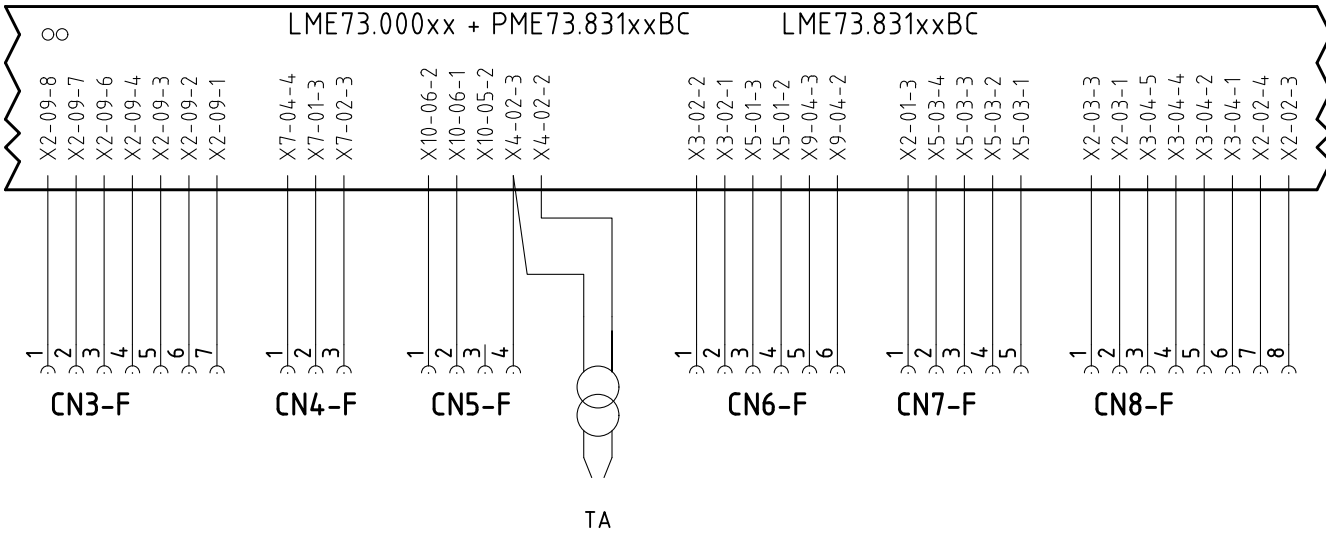

Data	23/09/2016	PREC.	FOGLIO
Revisione	01	8	9
Dis. N.	05 - 1140	SEGUE	TOTALE
		10	14

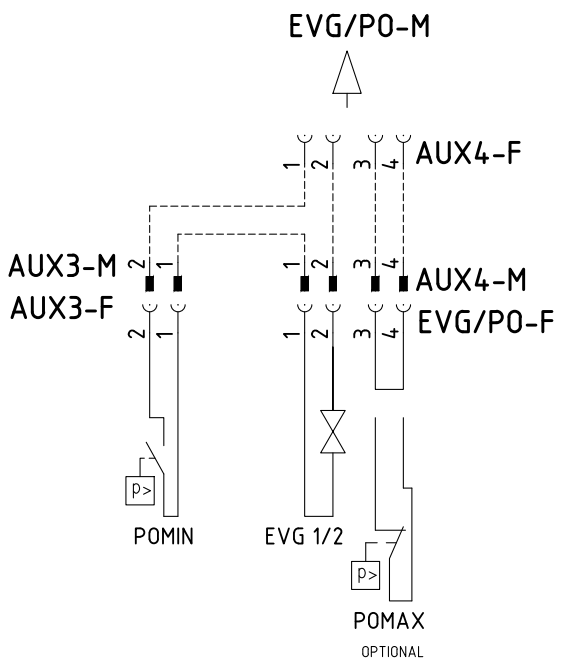
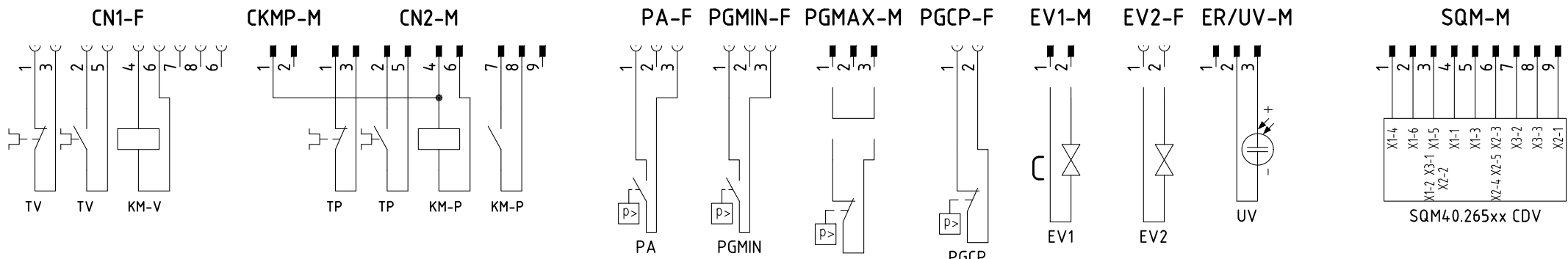

SOLO CON CONTROLLO TENUTA
WITH GAS LEAKAGE TEST ONLY

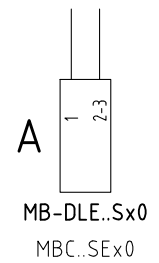
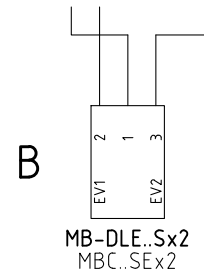

ESECUZIONE [A] = SOLO SENZA CONTROLLO TENUTA
[A] PERFORMANCE = WITHOUT GAS LEAKAGE ONLY

SERVOCOMANDO SERRANDA ARIA
AIR DAMPER ACTUATOR
SQM40.265Axx CDV

- I ALTA FIAMMA
HIGH FLAME
- II SOSTA
STAND-BY
- III BASSA FIAMMA GAS
GAS LOW FLAME
- IV BASSA FIAMMA GASOLIO
LIGHT OIL LOW FLAME
- V ACCENSIONE GASOLIO
LIGHT OIL IGNITION
- VI ACCENSIONE GAS
GAS IGNITION

Data	23/09/2016	PREC.	FOGLIO
Revisione	01	9	10
Dis. N.	05 - 1140	SEGUE	TOTALE
		11	14

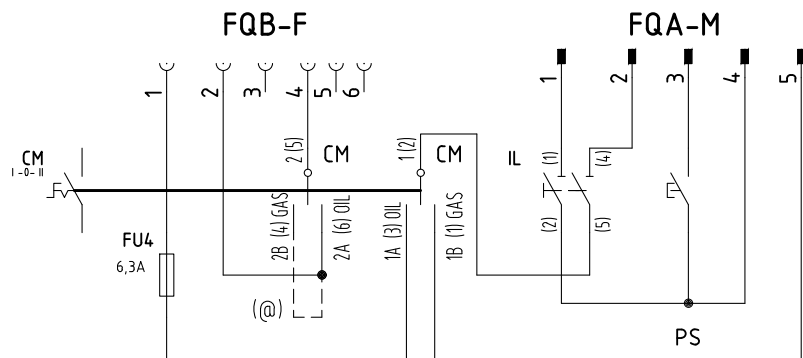
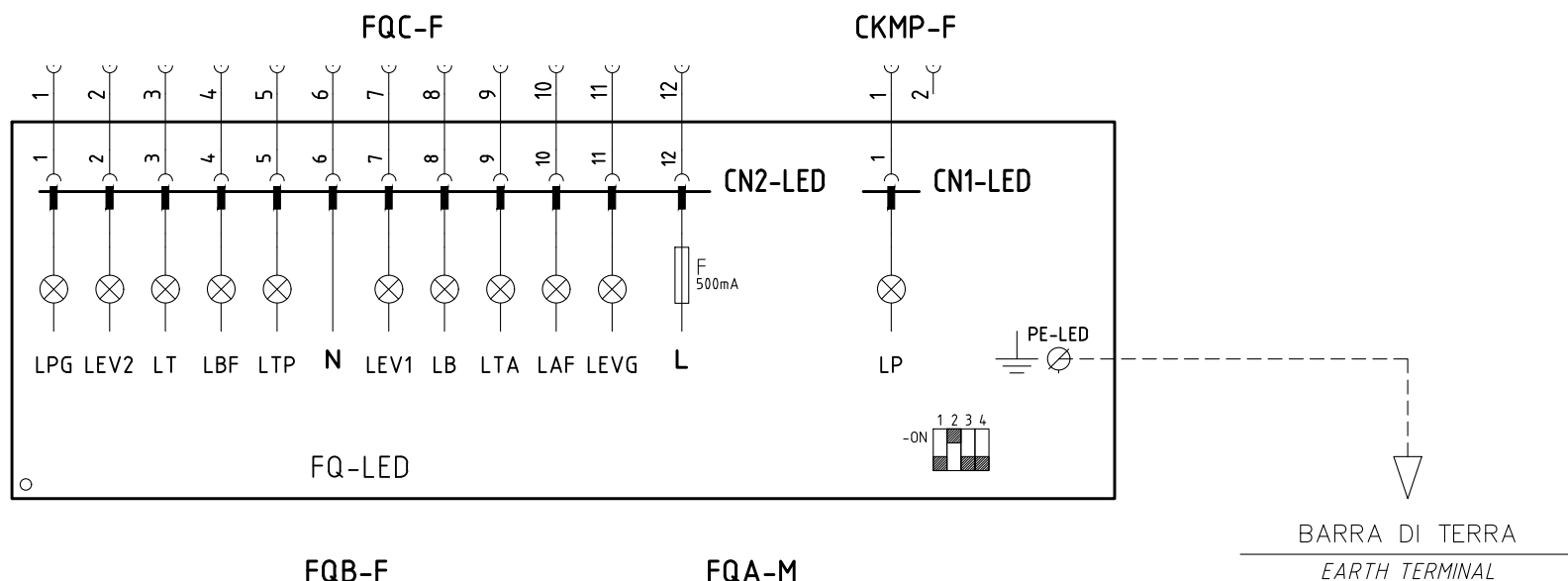

(@)
 PONTE PER VERSIONI SENZA CONTROLLO TENUTA
 BRIDGE FOR VERSION WITHOUT GAS LEAKAGE

Data	23/09/2016	PREC.	FOGLIO
Revisione	01	10	11
Dis. N.	05 - 1140	SEGUE	TOTALE
		12	14

Sigla/Item	Foglio/Sheet	Funzione	Function
600V RRR0-1-T73	7	REGOLATORE MODULANTE (ALTERNATIVO)	BURNER MODULATOR (ALTERNATIVE)
AZL2x..	6	INTERFACCIA UTENTE	USER INTERFACE
CM	1	SELETTORE MANUALE GAS -0- GASOLIO	MANUAL SWITCH GAS -0- LIGHT OIL
EV1	5	ELETTROVALVOLA GAS LATO RETE	UPSTREAM GAS SOLENOID VALVE
EV2	5	ELETTROVALVOLA GAS LATO BRUCIATORE	DOWNSTREAM GAS SOLENOID VALVE
EVG 1/2	5	ELETTROVALVOLE GASOLIO	LIGHT OIL ELECTRO VALVES
FQ-LED	11	PANNELLO FRONTALE (LED)	FRONT PANEL (LED)
FU1	1	FUSIBILE AUSILIARIO	AUXILIARY FUSE
FU2	7	FUSIBILE	FUSE
FU3	1	FUSIBILI LINEA POMPA	PUMP LINE FUSES
FU4	1	FUSIBILE AUSILIARIO	AUXILIARY FUSE
FU-A	1	FUSIBILI DI LINEA	LINE FUSES
FU-B	1	FUSIBILE DI LINEA	LINE FUSE
IG	1	INTERRUTTORE GENERALE	MAINS SWITCH
IL	1	INTERRUTTORE LINEA AUSILIARI	AUXILIARY LINE SWITCH
KA1	1	RELE" AUSILIARIO	AUXILIARY RELAY
KA2	1	RELE" AUSILIARIO	AUXILIARY RELAY
KA3	5	RELE" AUSILIARIO	AUXILIARY RELAY
KM3 HCRMMD	7	REGOLATORE MODULANTE (ALTERNATIVO)	BURNER MODULATOR (ALTERNATIVE)
KM-P	2	CONTATTORE MOTORE POMPA GASOLIO	LIGHT OIL PUMP MOTOR CONTACTOR
KM-V	2	CONTATTORE MOTORE VENTILATORE	FAN MOTOR CONTACTOR
LAF	6	LAMPADA SEGNALAZIONE ALTA FIAMMA BRUCIATORE	BURNER IN HIGH FLAME INDICATOR LIGHT
LB	2	LAMPADA SEGNALAZIONE BLOCCO BRUCIATORE	INDICATOR LIGHT FOR BURNER LOCK-OUT
LBF	5	LAMPADA SEGNALAZIONE BASSA FIAMMA BRUCIATORE	BURNER IN LOW FLAME INDICATOR LIGHT
LEV1	5	LAMPADA SEGNALAZIONE APERTURA [EV1]	INDICATOR LIGHT FOR OPENING OF ELECTRO-VALVE [EV1]
LEV2	5	LAMPADA SEGNALAZIONE APERTURA [EV2]	INDICATOR LIGHT FOR OPENING OF ELECTRO-VALVE [EV2]
LEV3	5	LAMPADA SEGNALAZIONE APERTURA [EV3]	INDICATOR LIGHT FOR OPENING OF ELECTRO-VALVE [EV3]
LME73.000xx + PME73.831xxBC	2	APPARECCHIATURA DI COMANDO	CONTROL SCHEME
LME73.831xxBC	2	APPARECCHIATURA DI COMANDO	CONTROL SCHEME
LP	2	LAMPADA SEGNALAZIONE FUNZIONAMENTO POMPA	INDICATOR LIGHT FOR PUMP OPERATION
LPG	4	LAMPADA SEGNALAZIONE PRESENZA GAS IN RETE	INDICATOR LIGHT FOR PRESENCE OF GAS IN THE NETWORK
LT	1	LAMPADA SEGNALAZIONE BLOCCO TERMICO MOTORE VENTILATORE	INDICATOR LIGHT FOR FAN MOTOR OVERLOAD THERMAL CUTOUT

Data	23/09/2016	PREC.	FOGLIO
Revisione	01	11	12
Dis. N.	05 - 1140	SEGUE	TOTALE
		13	14

Sigla/Item	Foglio/Sheet	Funzione	Function
LTA	4	LAMPADA SEGNALAZIONE TRASFORMATORE DI ACCENSIONE	IGNITION TRANSFORMER INDICATOR LIGHT
LTP	1	LAMPADA SEGNALAZIONE BLOCCO TERMICO MOTORE POMPA	INDICATOR LIGHT FOR PUMP MOTOR OVERLOAD THERMAL CUTOUT
MB-DLE..Sx0	5	GRUPPO VALVOLE GAS	GAS VALVES GROUP
MB-DLE..Sx2	5	GRUPPO VALVOLE GAS	GAS VALVES GROUP
MBC..SEx0	5	GRUPPO VALVOLE GAS (ALTERNATIVO)	GAS VALVES GROUP (ALTERNATIVE)
MBC..SEx2	5	GRUPPO VALVOLE GAS (ALTERNATIVO)	GAS VALVES GROUP (ALTERNATIVE)
MP	1	MOTORE POMPA GASOLIO	LIGHT OIL PUMP MOTOR
MV	1	MOTORE VENTILATORE	FAN MOTOR
PA	3	PRESSOSTATO ARIA	AIR PRESSURE SWITCH
PGCP	6	PRESSOSTATO GAS CONTROLLO PERDITE (OPTIONAL)	GAS LEAKAGE PRESSURE SWITCH (OPTIONAL)
PGMAX	6	PRESSOSTATO GAS DI MASSIMA PRESSIONE (OPTIONAL)	MAXIMUM PRESSURE GAS SWITCH (OPTIONAL)
PGMIN	4	PRESSOSTATO GAS DI MINIMA PRESSIONE	MINIMUM GAS PRESSURE SWITCH
POMAX	3	PRESSOSTATO DI MASSIMA PRESSIONE OLIO (OPTIONAL)	MAXIMUM OIL PRESSURE SWITCH (OPTIONAL)
POMIN	5	PRESSOSTATO DI MINIMA PRESSIONE OLIO	MINIMUM OIL PRESSURE SWITCH
PS	2	PULSANTE SBLOCCO FIAMMA	FLAME UNLOCK BUTTON
PT100	8	SONDA DI TEMPERATURA	TEMPERATURE PROBE
RWF50.2x	7	REGOLATORE MODULANTE (ALTERNATIVO)	BURNER MODULATOR (ALTERNATIVE)
RWF55.5x	7	REGOLATORE MODULANTE (ALTERNATIVO)	BURNER MODULATOR (ALTERNATIVE)
SD-PRESS	8	SONDA DI PRESSIONE	PRESSURE PROBE
SD-TEMP.	8	SONDA DI TEMPERATURA	TEMPERATURE PROBE
SD - 0÷10V	8	TRASDUTTORE USCITA IN TENSIONE	TRANSDUCER VOLTAGE OUTPUT
SD - 4÷20mA	8	TRASDUTTORE USCITA IN CORRENTE	TRANSDUCER CURRENT OUTPUT
SMA	7	SELETTORE MANUALE/AUTOMATICO	MANUAL/AUTOMATIC SWITCH
SMF	7	SELETTORE MANUALE FUNZIONAMENTO MIN-0-MAX	MIN-0-MAX MANUAL OPERATION SWITCH
SQM40.265Axx CDV	6	SERVOCOMANDO SERRANDA ARIA	AIR DAMPER ACTUATOR
ST	4	SERIE TERMOSTATI/PRESSOSTATI	SERIES OF THERMOSTATS OR PRESSURE SWITCHES
TA	4	TRASFORMATORE DI ACCENSIONE	IGNITION TRANSFORMER
TAB	4	TERMOSTATO/PRESSOSTATO ALTA-BASSA FIAMMA	HIGH-LOW THERMOSTAT/PRESSURE SWITCHES
TC	8	TERMOCOPPIA	THERMOCOUPLE
TP	1	TERMICO MOTORE POMPA	PUMP MOTOR THERMAL
TV	1	TERMICO MOTORE VENTILATORE	FAN MOTOR THERMAL
UV	6	SONDA UV RILEVAZIONE FIAMMA	UV FLAME DETECTOR

Data	23/09/2016	PREC.	FOGLIO
Revisione	01	12	13
Dis. N.	05 - 1140	SEGUE	TOTALE
		14	14

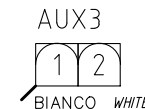
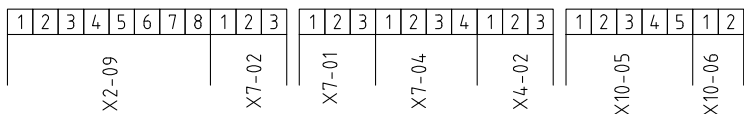
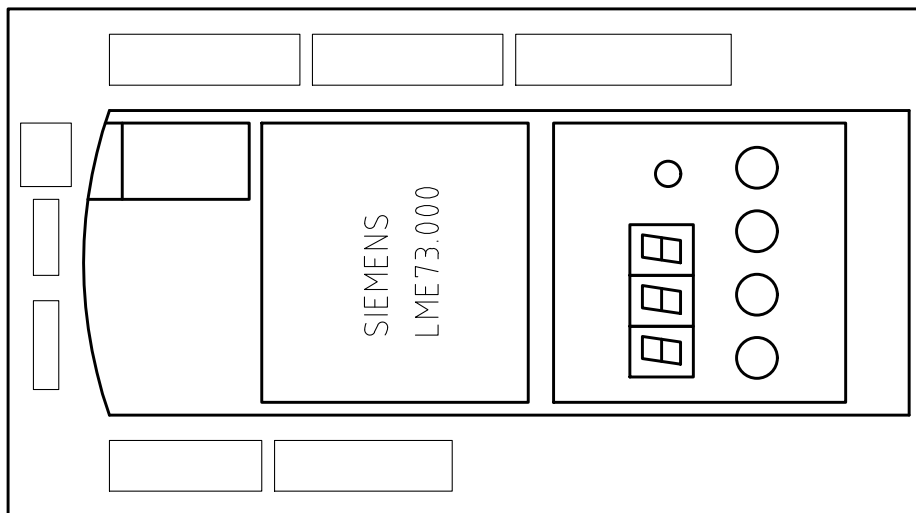
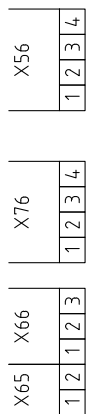
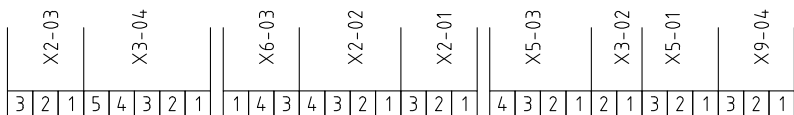

VISTA LATO COMPONENTI
COMPONENTS SIDE VIEW

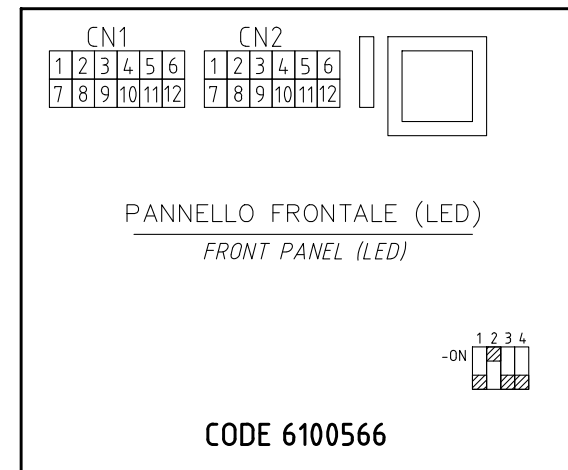
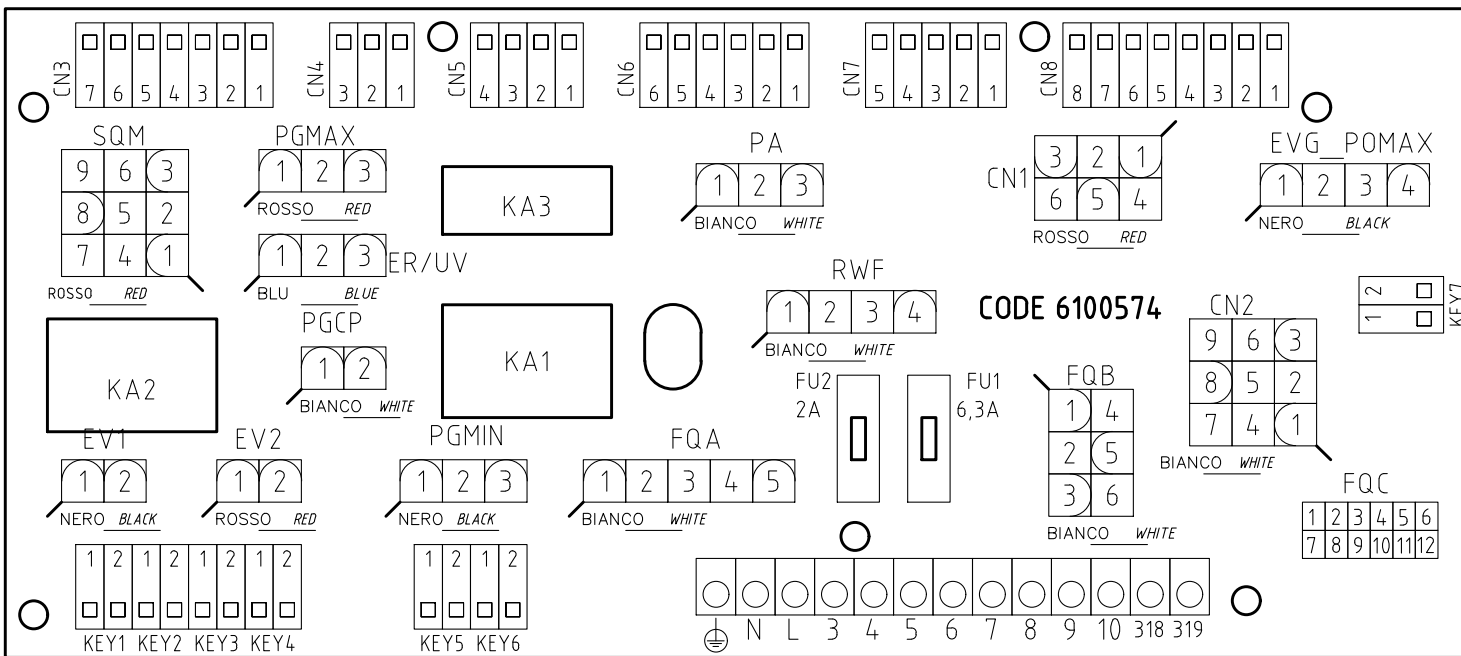
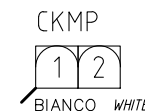

Data	23/09/2016	PREC.	FOGLIO
Revisione	01	13	14
Dis. N.	05 - 1140	SEGUE	TOTALE
		/	14