

VERSIONE MONOSTADIO "TN"  
"TN" SINGLE-STAGE VERSION

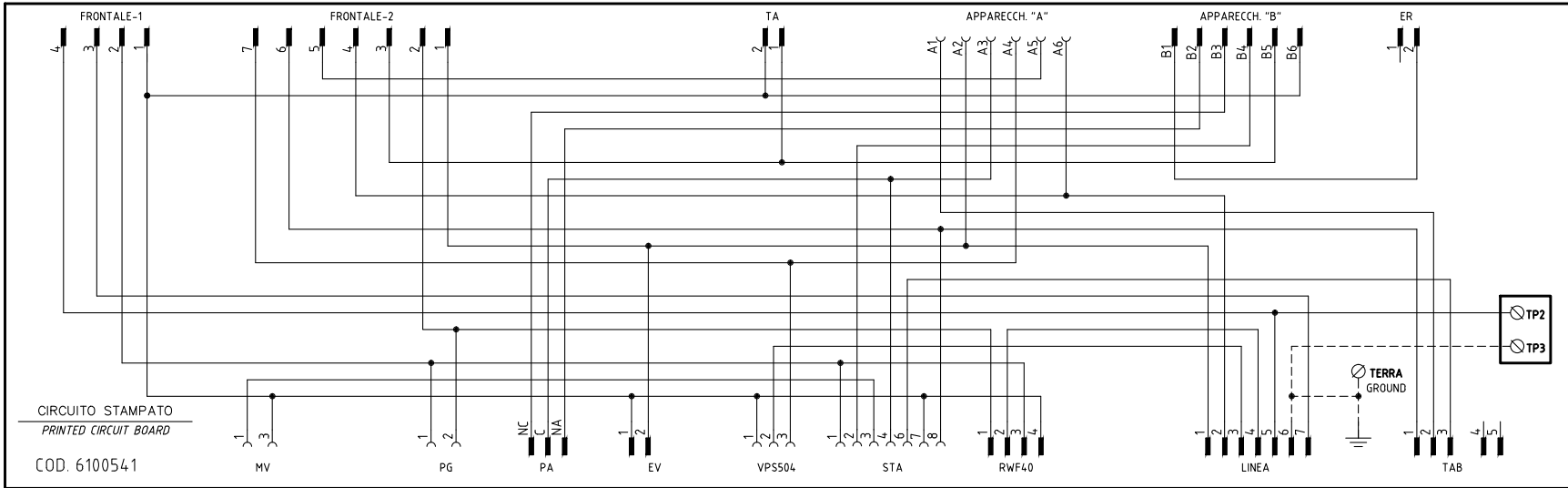

COD. 6100541

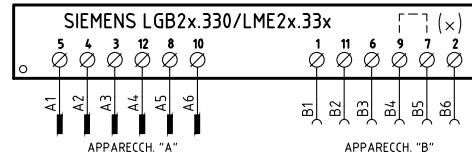
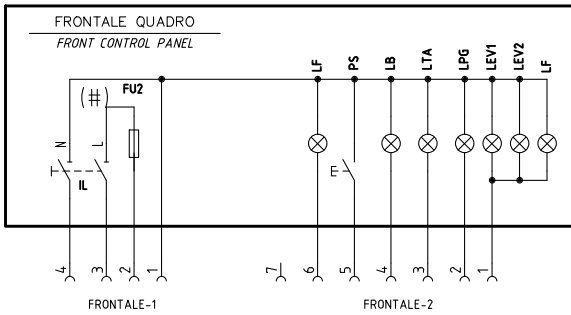
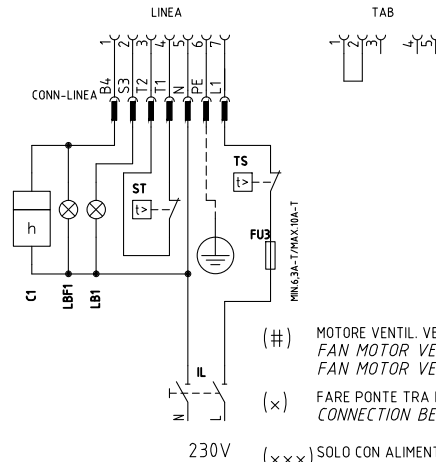
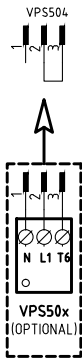
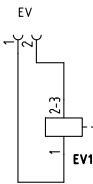
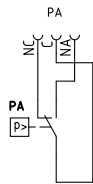
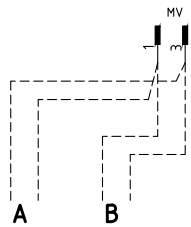

- (#) MOTORE VENTIL. VERSIONE [A], FU2 = 6,3A F; MOTORE VENTIL. VERSIONE [B], FU2 = 10A F  
FAN MOTOR VERSION [A], FU2 = 6,3 A F;  
FAN MOTOR VERSION [B], FU2 = 10 A F
- (x) FARE PONTE TRA I MORSETTI 7 E 9 SOLO CON LGB21.330  
CONNECTION BETWEEN TERMINALS 7 AND 9 WITH LGB21.330 ONLY
- (x x x) SOLO CON ALIMENTAZIONE ELETTRICA SENZA NEUTRO  
WITH ELECTRIC SUPPLY WITHOUT NEUTRAL VERSION ONLY

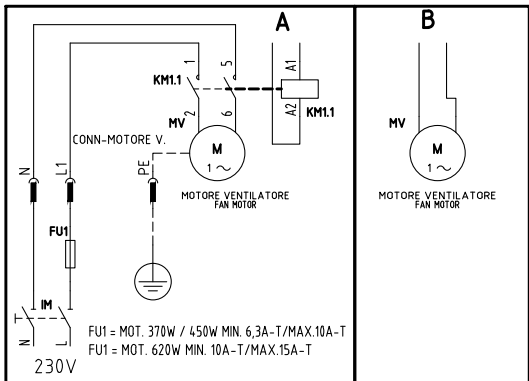

Impianto  
**TIPI/TYPES NG(X)350/400/550 - LG(X)350/400/550**  
**MODELLI/MODELS x-.TN(PR)(MD).x.xx.A.x.xx**

Descrizione  
**VERSIONE CON CIRCUITO STAMPATO**  
**WITH PRINTED CIRCUIT VERSION**

Ordine  
Commissa  
Esecutore  
U. PINTON

Data Controllato  
07/08/2014

Controllato  
E. CAVALLI

Data	19/10/2010	PREC.	FOGLIO
Revisione	<b>05</b>	/	<b>1</b>
Dis. N.	<b>18 - 0163</b>	SEGUE	TOTALE
		<b>2</b>	<b>5</b>

REV.	MODIFICA	DATA	FIRME
05	AGGIUNTO/ADDED "KVB" ASCON	07/08/14	U. PINTON
04	AGGIUNTO/ADDED "600V"	19/06/12	U. PINTON
03	AGGIUNTO/ADDED "RWF502x"	20/01/12	U. PINTON
02	MOTOR MODIFY	19/10/10	U. PINTON
01	AGGIUNTO / ADDED SGM72...	22/05/09	U. PINTON

VERSIONE ALTA-BASSA FIAMMA "AB" / PROGRESSIVO "PR"  
 "AB" HIGH-LOW / "PR" PROGRESSIVE VERSION

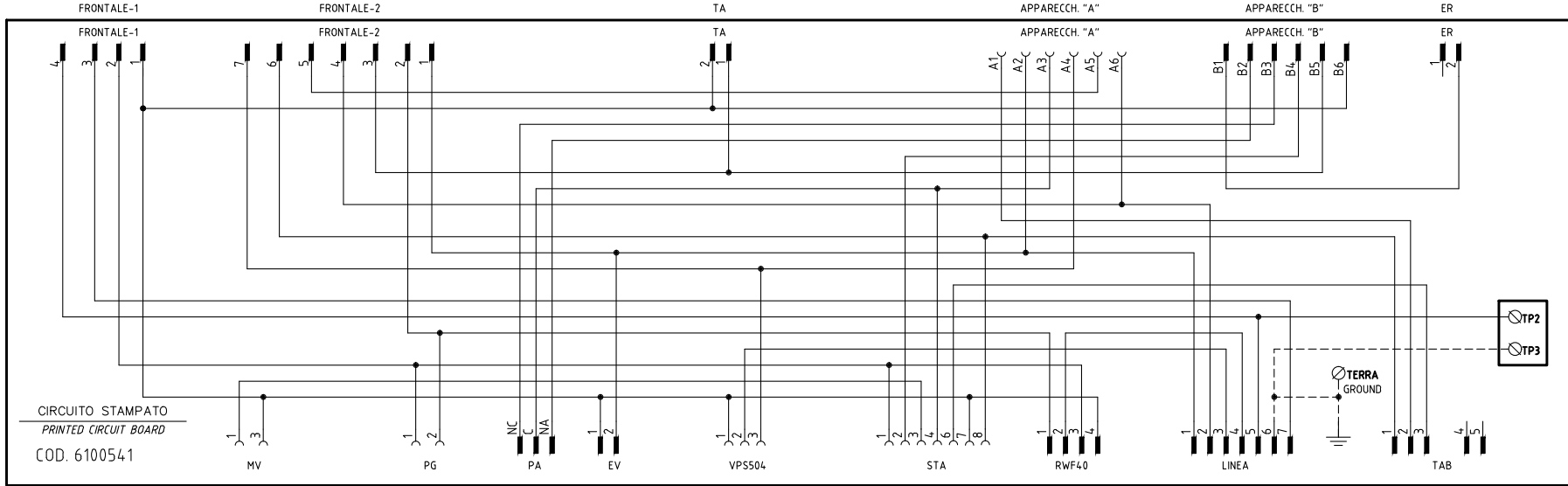
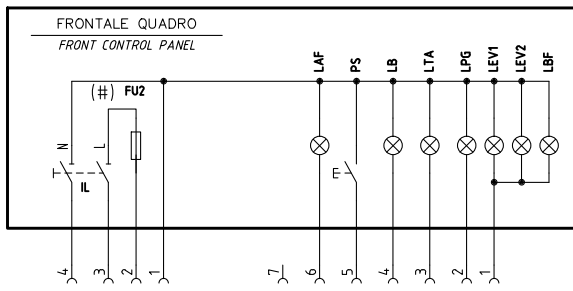

SERVOCOMANDO SERRANDA ARIA  
 AIR DAMPER ACTUATOR  
 STA13B0.36/83N30L

I ALTA FIAMMA  
 HIGH FLAME  
 SOSTA  
 STAND-BY  
 II BASSA FIAMMA  
 LOW FLAME  
 III NON USATA  
 NOT USED

SERVOCOMANDO SERRANDA ARIA  
 AIR DAMPER ACTUATOR  
 SIEMENS SQNT2.xA4.A20

I (ROSSO) ALTA FIAMMA  
 HIGH FLAME  
 II (BLU) SOSTA  
 STAND-BY  
 III (ARANCIO) BASSA FIAMMA  
 LOW FLAME  
 IV (NERO) NON USATA  
 NOT USED

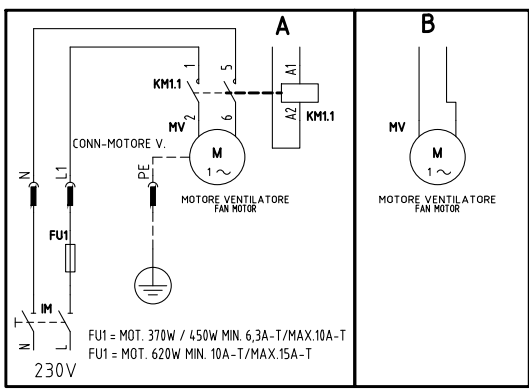
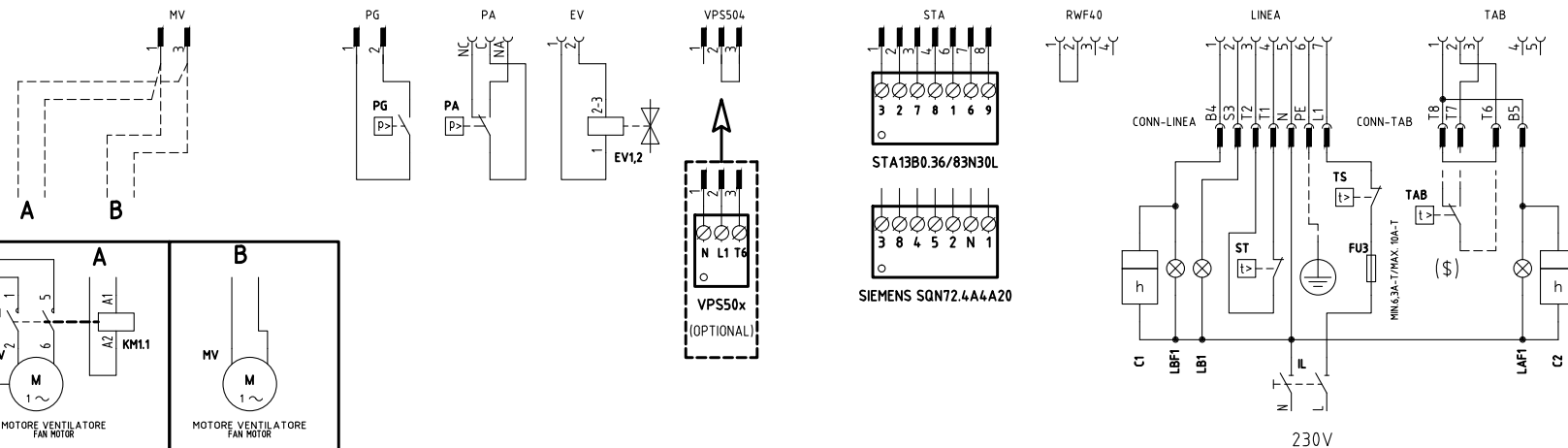

(#) MOTORE VENTIL. VERSIONE [A], FU2 = 6,3A F; MOTORE VENTIL. VERSIONE [B], FU2 = 10A F  
 FAN MOTOR VERSION [A], FU2 = 6,3 A F;  
 FAN MOTOR VERSION [B], FU2 = 10 A F

(x x x) SOLO CON ALIMENTAZIONE ELETTRICA SENZA NEUTRO  
 WITH ELECTRIC SUPPLY WITHOUT NEUTRAL VERSION ONLY

(\$) SE USATO "TAB", TOGLIERE IL PONTE TRA I MORSETTI T6-T8  
 IF USED "TAB", REMOVE THE BRIDGE BETWEEN TERMINALS T6-T8

Data	19/10/2010	PREC.	FOGLIO
Revisione	05	1	2
Dis. N.	18 - 0163	SEGUE	TOTALE
		3	5

VERSIONE MODULANTE "MD"  
"MD" MODULATING VERSION

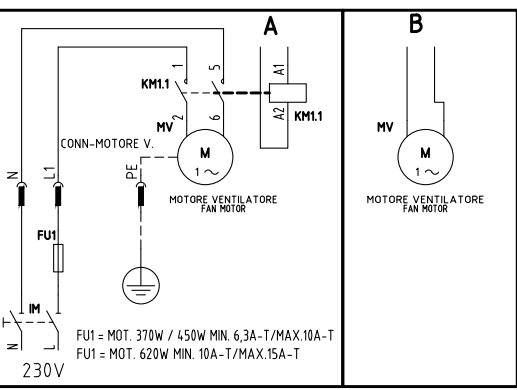
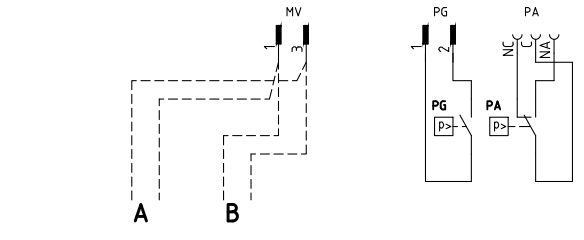
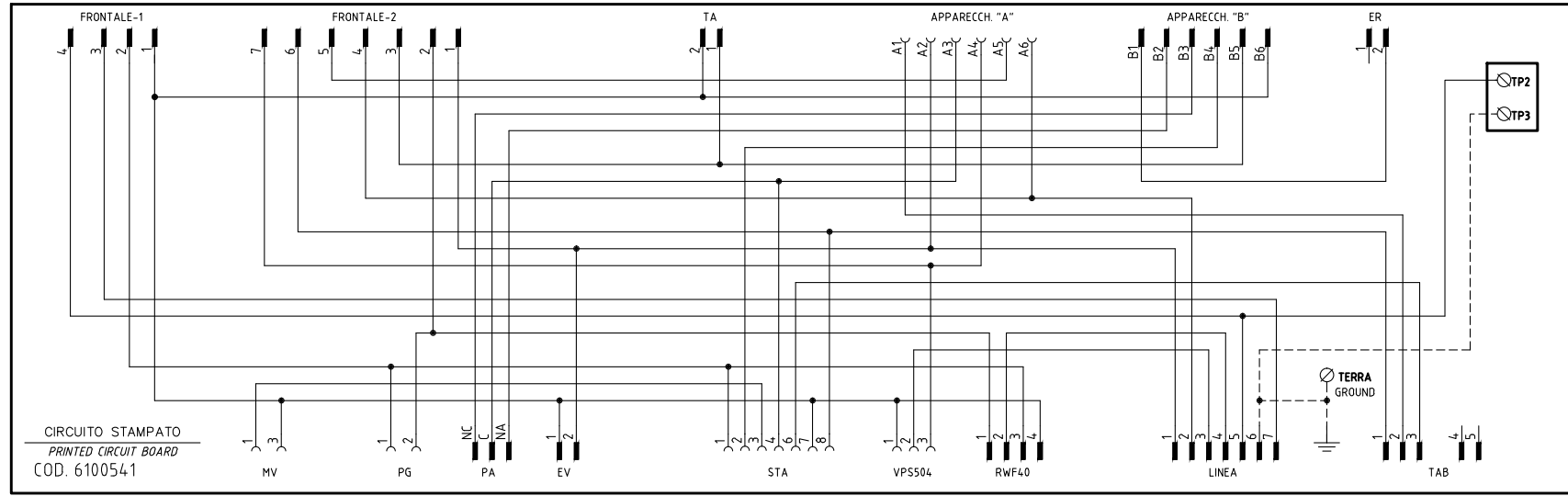
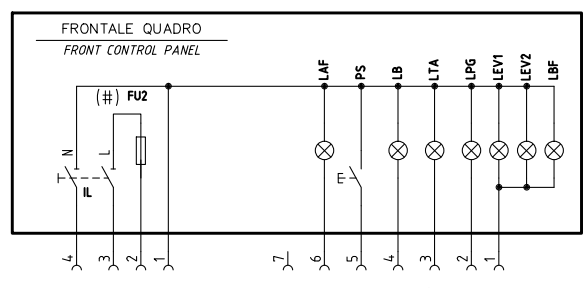

SERVOCOMANDO SERRANDA ARIA  
AIR DAMPER ACTUATOR  
STA13B0.36/83N30L

I ALTA FIAMMA HIGH FLAME  
II SOSTA STAND-BY  
III BASSA FIAMMA LOW FLAME  
IV NON USATA NOT USED

SERVOCOMANDO SERRANDA ARIA  
AIR DAMPER ACTUATOR  
SIEMENS SQN72.xA4.A20

I (ROSSO) ALTA FIAMMA HIGH FLAME  
II (BLU) SOSTA STAND-BY  
III (ARANCIO) BASSA FIAMMA LOW FLAME  
IV (NERO) NON USATA NOT USED

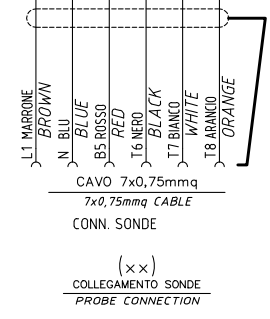
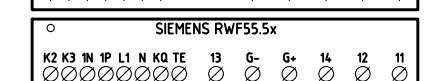
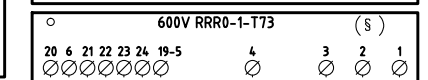
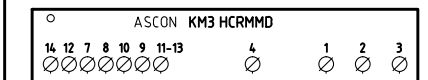
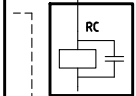
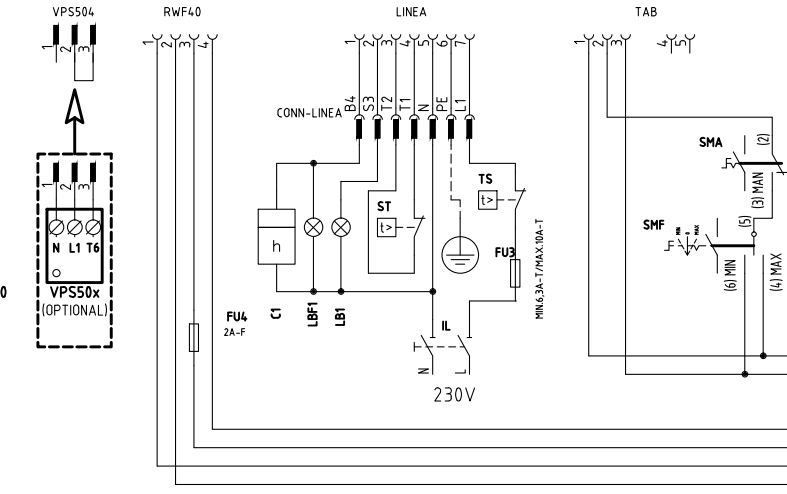
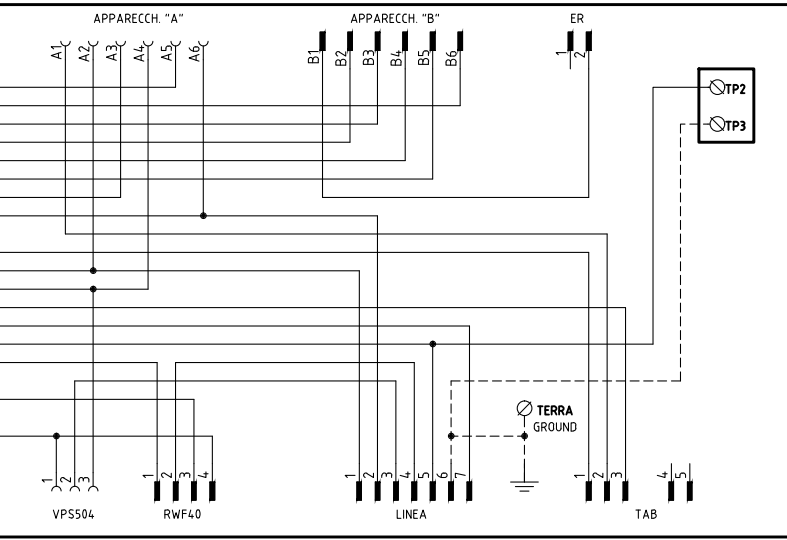
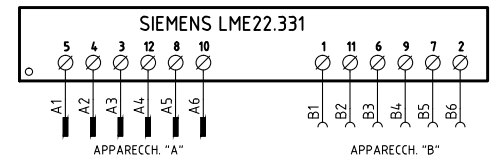

(#) MOTORE VENTIL. VERSIONE [A], FU2 = 6,3A F; MOTORE VENTIL. VERSIONE [B], FU2 = 10A F  
FAN MOTOR VERSION [A], FU2= 6,3 A F;  
FAN MOTOR VERSION [B], FU2= 10 A F

(x x x) SOLO CON ALIMENTAZIONE ELETTRICA SENZA NEUTRO  
WITH ELECTRIC SUPPLY WITHOUT NEUTRAL VERSION ONLY

Data	19/10/2010	PREC.	FOGLIO
Revisione	05	2	3
Dis. N.	18 - 0163	SEQUE	TOTALE
		4	5

(xx)  
 ATTENZIONE COLLEGAMENTO SONDE CON CONNETTORE 7 POLI  
 WARNING PROBE CONNECTION WITH 7 PINS CONNECTOR

### KM3 HCRMMD

### 600V RRR0-1-T73

### RWF55.5x

### RWF50.2x

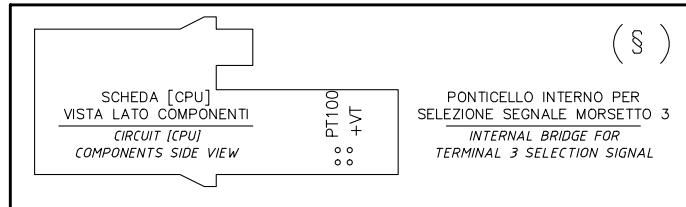
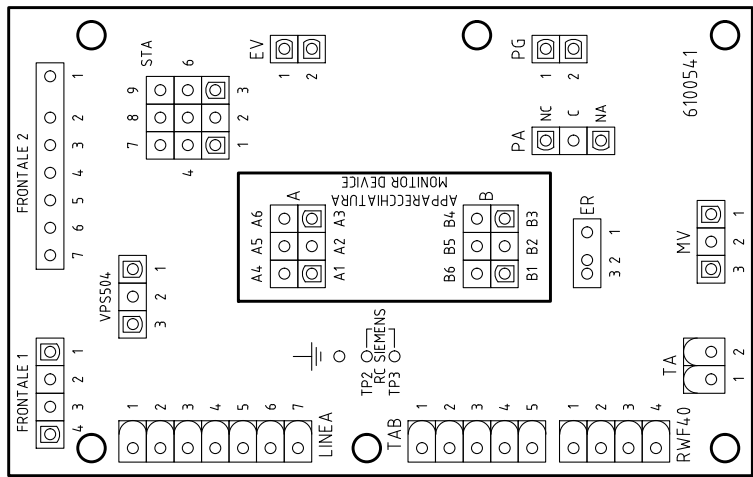
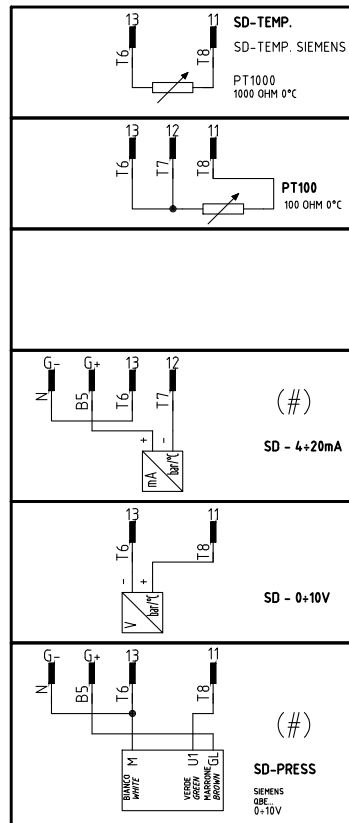
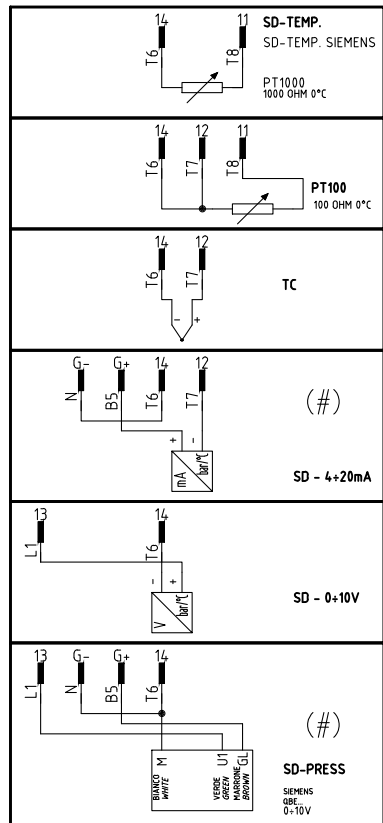
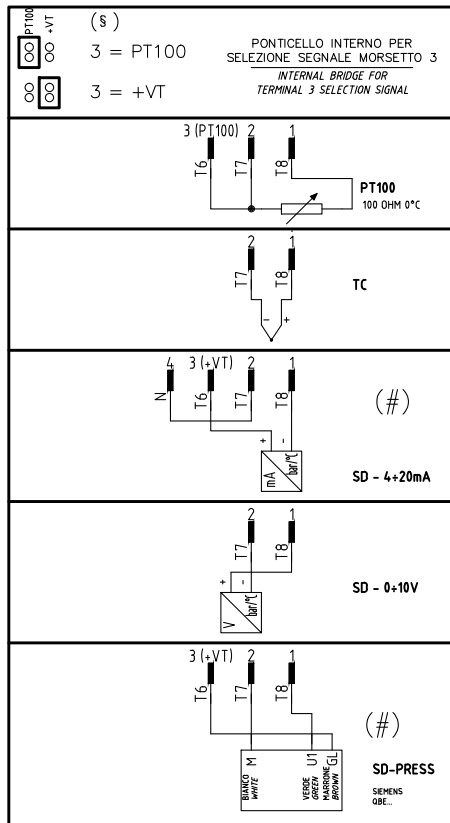
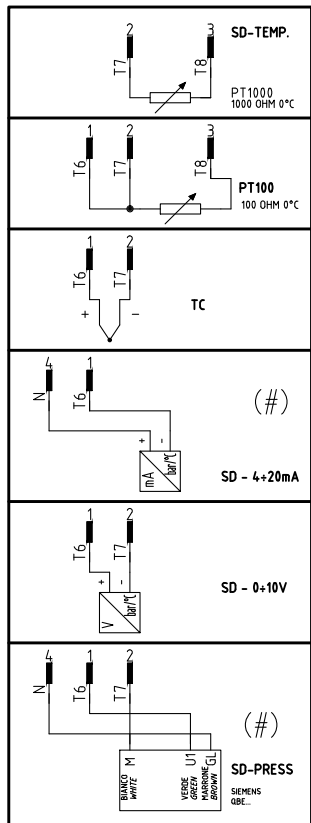

Data	19/10/2010	PREC.	FOGLIO
Revisione	05	3	4
Dis. N.	18 - 0163	SEGUE	TOTALE
		5	5

Sigla/Item	Funzione	Function
600V RRR0-1-T73	REGOLATORE MODULANTE (ALTERNATIVO)	BURNER MODULATOR (ALTERNATIVE)
C1	CONTAORE BASSA FIAMMA	LOW FLAME TIME COUNTER
C2	CONTAORE ALTA FIAMMA	HIGH FLAME TIME COUNTER
ER	ELETTRODO RILEVAZIONE FIAMMA	FLAME DETECTION ELECTRODE
EV1,2	ELETTROVALVOLE GAS (O GRUPPO VALVOLE)	GAS ELECTRO-VALVES (OR VALVES GROUP)
FU1	FUSIBILE LINEA MOTORE VENTILATORE	FAN MOTOR LINE FUSE
FU2	FUSIBILE DI LINEA	LINE FUSE
FU3	FUSIBILE DI LINEA	LINE FUSE
FU4	FUSIBILE AUSILIARIO	AUXILIARY FUSE
IL	INTERRUTTORE LINEA BRUCIATORE	BURNER LINE SWITCH
IM	INTERRUTTORE LINEA MOTORE VENTILATORE	FAN MOTOR LINE SWITCH
KM1.1	CONTATTORE MOTORE VENTILATORE	FAN MOTOR CONTACTOR
KM3 HCRMMD	REGOLATORE MODULANTE (ALTERNATIVO)	BURNER MODULATOR (ALTERNATIVE)
LAF	LAMPADA SEGNALAZIONE ALTA FIAMMA BRUCIATORE	BURNER IN HIGH FLAME INDICATOR LIGHT
LAF1	LAMPADA SEGNALAZIONE ALTA FIAMMA BRUCIATORE	BURNER IN HIGH FLAME INDICATOR LIGHT
LB	LAMPADA SEGNALAZIONE BLOCCO BRUCIATORE	INDICATOR LIGHT FOR BURNER LOCK-OUT
LB1	LAMPADA SEGNALAZIONE BLOCCO BRUCIATORE	INDICATOR LIGHT FOR BURNER LOCK-OUT
LBF	LAMPADA SEGNALAZIONE BASSA FIAMMA BRUCIATORE	BURNER IN LOW FLAME INDICATOR LIGHT
LBF1	LAMPADA SEGNALAZIONE BASSA FIAMMA BRUCIATORE	BURNER IN LOW FLAME INDICATOR LIGHT
LEV1	LAMPADA SEGNALAZIONE APERTURA [EV1]	INDICATOR LIGHT FOR OPENING OF ELECTRO-VALVE [EV1]
LEV2	LAMPADA SEGNALAZIONE APERTURA [EV2]	INDICATOR LIGHT FOR OPENING OF ELECTRO-VALVE [EV2]
LF	LAMPADA SEGNALAZIONE FUNZIONAMENTO BRUCIATORE	INDICATOR LIGHT BURNER OPERATION
LPG	LAMPADA SEGNALAZIONE PRESENZA GAS IN RETE	INDICATOR LIGHT FOR PRESENCE OF GAS IN THE NETWORK
LTA	LAMPADA SEGNALAZIONE TRASFORMATORE DI ACCENSIONE	IGNITION TRANSFORMER INDICATOR LIGHT
MV	MOTORE VENTILATORE	FAN MOTOR
PA	PRESSOSTATO ARIA	AIR PRESSURE SWITCH
PG	PRESSOSTATO GAS DI MINIMA PRESSIONE	MINIMUM GAS PRESSURE SWITCH
PS	PULSANTE SBLOCCO FIAMMA	FLAME UNLOCK BUTTON
PT100	SONDA DI TEMPERATURA	TEMPERATURE PROBE
RC	CIRCUITO RC	RC CIRCUIT
SD-PRESS	SONDA DI PRESSIONE	PRESSURE PROBE
SD-TEMP.	SONDA DI TEMPERATURA	TEMPERATURE PROBE
SD - 0÷10V	TRASDUTTORE USCITA IN TENSIONE	TRANSDUCER VOLTAGE OUTPUT
SD - 4÷20mA	TRASDUTTORE USCITA IN CORRENTE	TRANSDUCER CURRENT OUTPUT
SIEMENS LGB2x.330/LME2x.33x	APPARECCHIATURA CONTROLLO FIAMMA	CONTROL BOX
SIEMENS LME22.331	APPARECCHIATURA CONTROLLO FIAMMA	CONTROL BOX
SIEMENS RWF50.2x	REGOLATORE MODULANTE	BURNER MODULATOR
SIEMENS RWF55.5x	REGOLATORE MODULANTE (ALTERNATIVO)	BURNER MODULATOR (ALTERNATIVE)
SIEMENS SQN72.4A4A20	SERVOCOMANDO SERRANDA ARIA (ALTERNATIVO)	AIR DAMPER ACTUATOR (ALTERNATIVE)
SMA	SELETTORE MANUALE/AUTOMATICO	MANUAL/AUTOMATIC SWITCH
SMF	SELETTORE MANUALE FUNZIONAMENTO MIN-0-MAX	MIN-0-MAX MANUAL OPERATION SWITCH
ST	SERIE TERMOSTATI/PRESSOSTATI	SERIES OF THERMOSTATS OR PRESSURE SWITCHES
STA13B0.36/83N30L	SERVOCOMANDO SERRANDA ARIA	AIR DAMPER ACTUATOR
TA	TRASFORMATORE DI ACCENSIONE	IGNITION TRANSFORMER
TAB	TERMOSTATO/PRESSOSTATO ALTA-BASSA FIAMMA	HIGH-LOW THERMOSTAT/PRESSURE SWITCHES
TC	TERMOCOPPIA	THERMOCOUPLE
TS	TERMOSTATO/PRESSOSTATO DI SICUREZZA	SAFETY THERMOSTAT OR PRESSURE SWITCH
VPS50x	CONTROLLO DI TENUTA VALVOLE GAS (OPTIONAL)	GAS PROVING SYSTEM (OPTIONAL)

Data	19/10/2010	PREC.	FOGLIO
Revisione	05	4	5
Dis. N.	18 - 0163	SEGUE	TOTALE
		/	5