

02	ELIMINATO SELETORE "CMF"/REMOVED "CMF" SWITCH	25/11/13	U. PINTON
01	AGGIUNTO/ADDED "POMAX"	20/07/12	U. PINTON
REV.	MODIFICA	DATA	FIRME



Impianto
TIPI/TYPES RG1030 / RG1040
MODELLO/MODEL G-.PR.S.xx.A

Descrizione

Ordine

Commissa

Esecutore
U. PINTON

Data Controllato
20/07/2012

Controllato
S. MARCHETTI

Data 05/07/2011

Revisione **02**

Dis. N. **12 - 0186**

PREC. /

SEGUE 2

FOGLIO 1

TOTALE 6

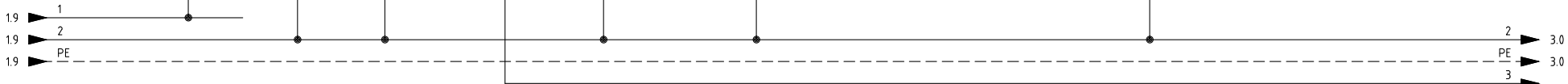
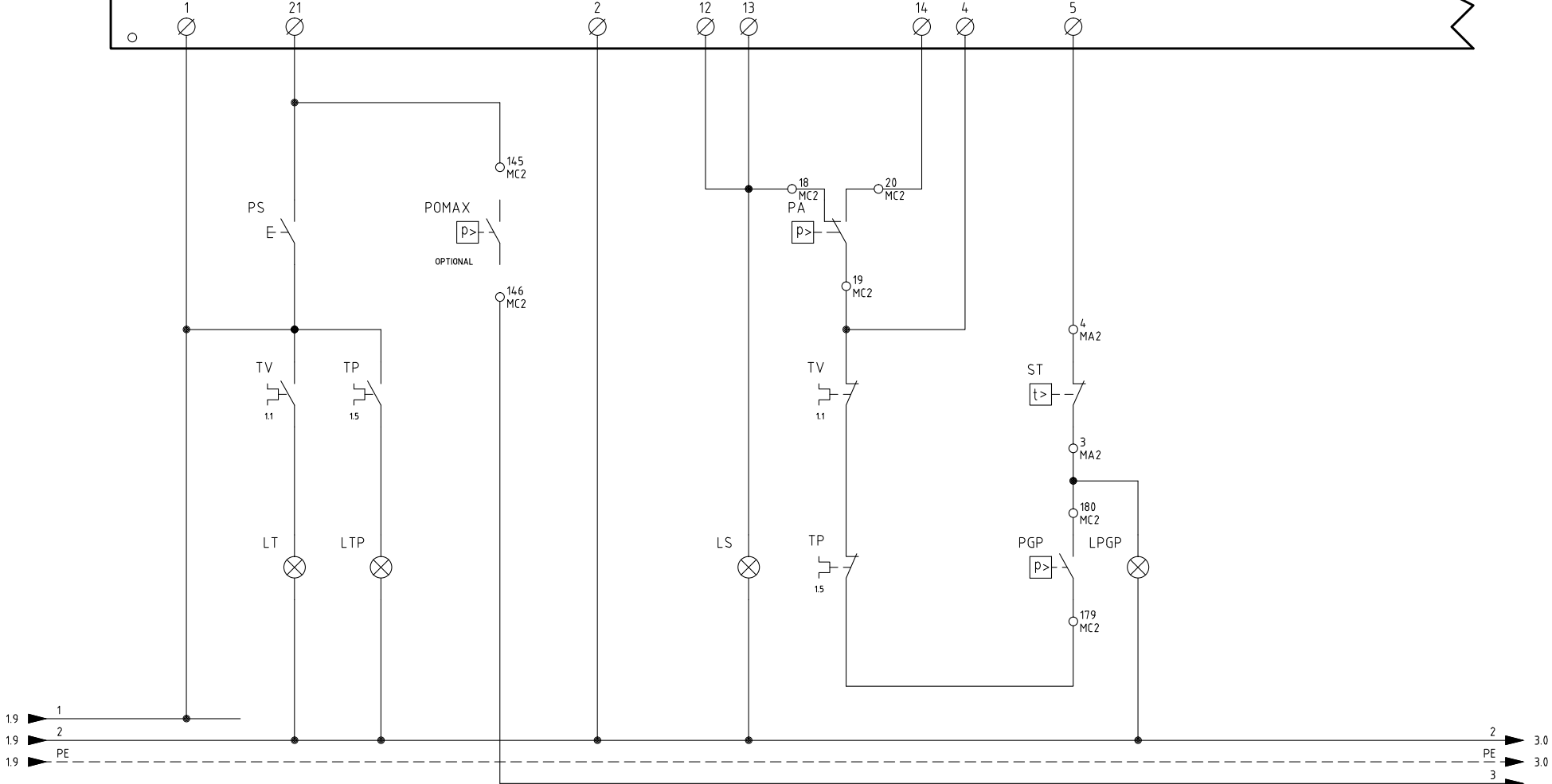
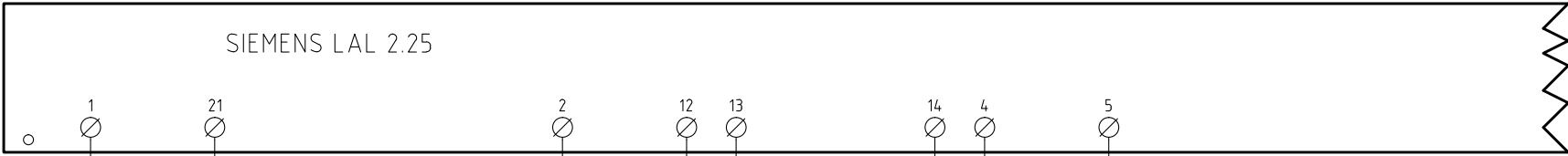

Data	05/07/2011	PREC.	FOGLIO
Revisione	02	1	2
Dis. N.	12 - 0186	SEGUE	TOTALE
		3	6

SIEMENS LAL 2.25

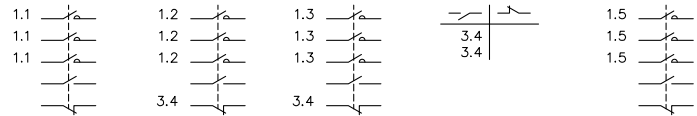
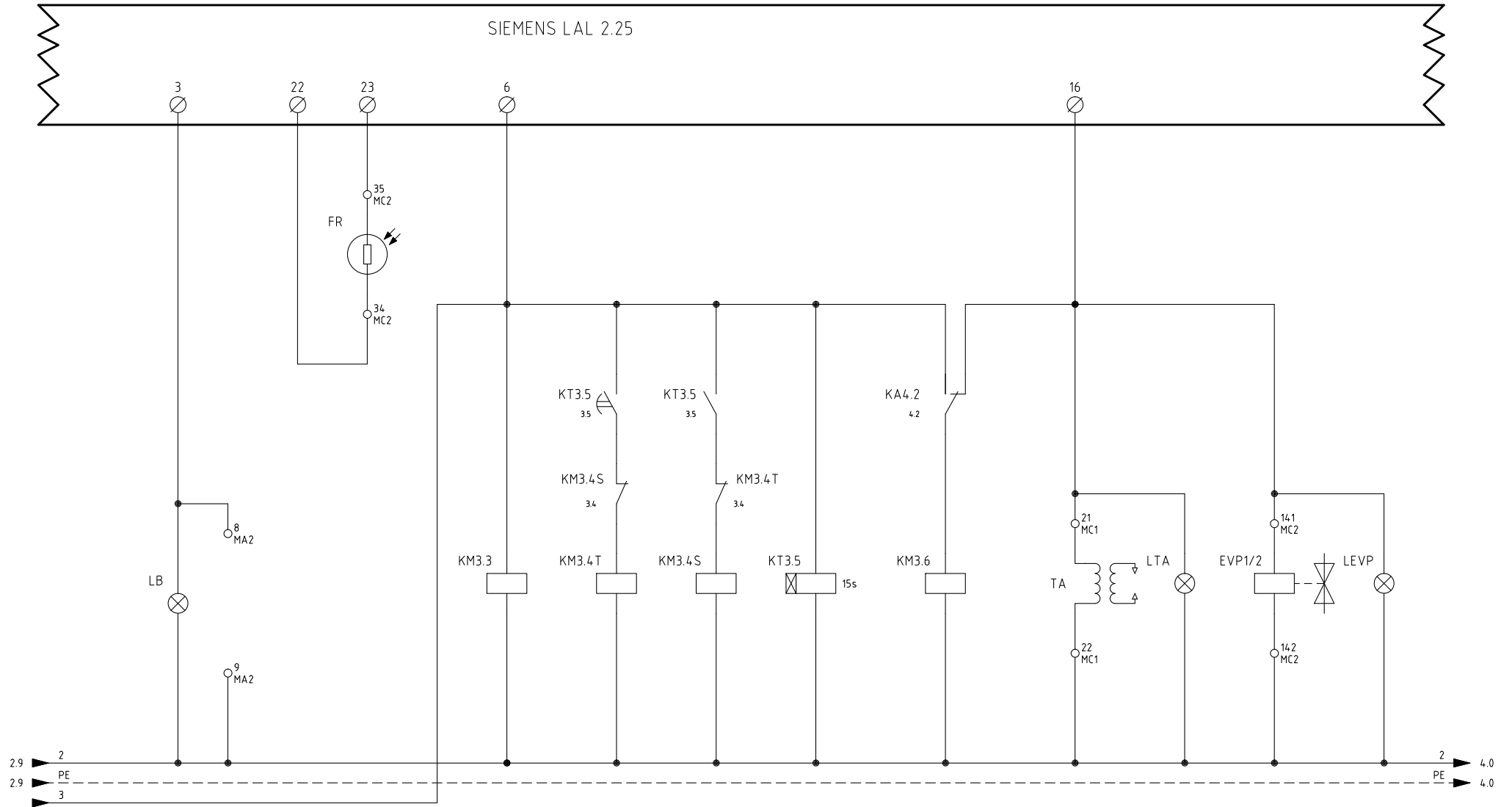

Data	05/07/2011	PREC.	FOGLIO
Revisione	02	2	3
Dis. N.	12 - 0186	SEGUE	TOTALE
		4	6

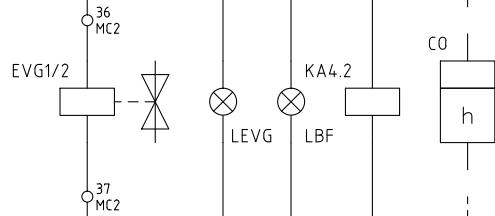

KA4.2
4.2

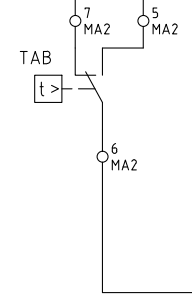
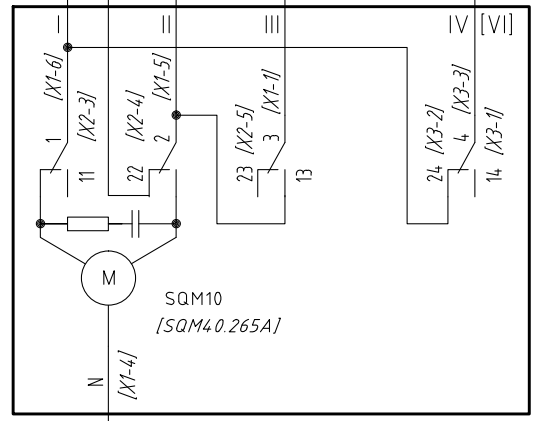

3.9 2
3.9 PE

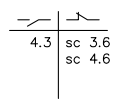

Data	05/07/2011	PREC.	FOGLIO
Revisione	02	3	4
Dis. N.	12 - 0186	SEGUE	TOTALE
		5	6

QUADRO QG - MORSETTIERA MA1
MORSETTIERA ALIMENTAZIONE - PIASTRA 1
SUPPLY TERMINALS - PLATE 1

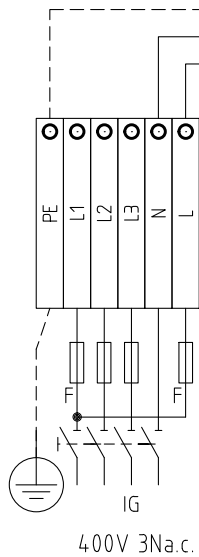

QUADRO QG - MORSETTIERA MA2
MORSETTIERA ALIMENTAZIONE - PIASTRA 2
SUPPLY TERMINALS - PLATE 2

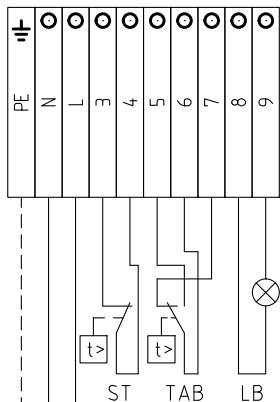

QUADRO QG - MORSETTIERA MC1
MORSETTIERA COMPONENTI BRUCIATORE - PIASTRA 1
BURNER COMPONENTS TERMINALS - PLATE 1

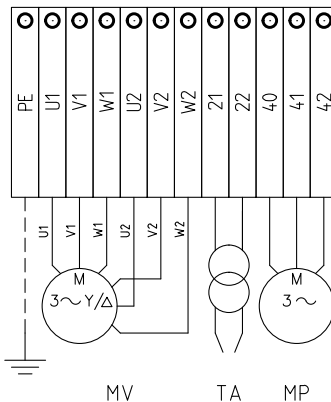

QUADRO QG - MORSETTIERA MC2
MORSETTIERA COMPONENTI BRUCIATORE - PIASTRA 2
BURNER COMPONENTS TERMINALS - PLATE 2

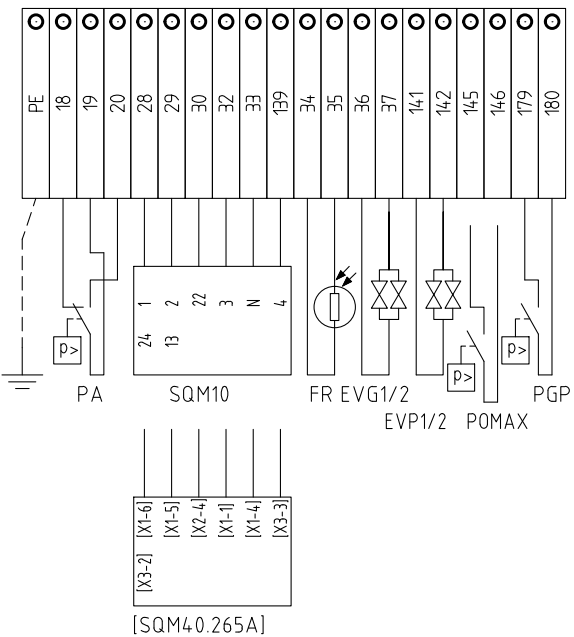

SERVOCOMANDO SERRANDA ARIA
AIR DAMPER ACTUATOR
SQM10

- I ALTA FIAMMA
HIGH FLAME
- II SOSTA E ACCENSIONE
STAND-BY AND IGNITION
- III BASSA FIAMMA
LOW FLAME
- IV LIMITAZIONE CORSA ANTICIPO SERVOCOMANDO
ACTUATOR AUTOMATIC ADVANCE RESTRICTION

SERVOCOMANDO SERRANDA ARIA (ALTERNATIVO)
AIR DAMPER ACTUATOR (ALTERNATIVE)
SQM40.265

- I ALTA FIAMMA
HIGH FLAME
- II SOSTA E ACCENSIONE
STAND-BY AND IGNITION
- III BASSA FIAMMA
LOW FLAME
- VI LIMITAZIONE CORSA ANTICIPO SERVOCOMANDO
ACTUATOR AUTOMATIC ADVANCE RESTRICTION

Data	05/07/2011	PREC.	FOGLIO
Revisione	02	4	5
Dis. N.	12 - 0186	SEGUE	TOTALE
		6	6

SIGLA/ITEM	FOGLIO/SHEET	FUNZIONE	FUNCTION
CO	4	CONTAORE DI FUNZIONAMENTO (OPTIONAL)	OPERATION TIME COUNTER (OPTIONAL)
EVG1/2	4	ELETTROVALVOLE GASOLIO	LIGHT OIL ELECTRO VALVE
EVPI/2	3	ELETTROVALVOLE PILOTA GAS	PILOT GAS ELECTRO-VALVES
FR	3	FOTORESISTENZA RILEVAZIONE FIAMMA	PHOTORESISTOR FLAME DETECTOR
FU1.2	1	FUSIBILI LINEA BRUCIATORE	BURNER LINE FUSES
FU1.5	1	FUSIBILI LINEA POMPA	PUMP LINE FUSES
FU1.7	1	FUSIBILE LINEA AUSILIARI	AUXILIARY LINE FUSE
IG	1	INTERRUTTORE LINEA BRUCIATORE	BURNER LINE SWITCH
IL	1	INTERRUTTORE LINEA AUSILIARI	AUXILIARY LINE SWITCH
KA4.2	4	RELE' AUSILIARIO	AUXILIARY RELAY
KM3.3	3	CONTATTORE MOTORE VENTILATORE (LINEA)	FAN MOTOR CONTACTOR (LINE)
KM3.4S	3	CONTATTORE MOTORE VENTILATORE (STELLA)	FAN MOTOR CONTACTOR (STAR)
KM3.4T	3	CONTATTORE MOTORE VENTILATORE (TRIANGOLO)	FAN MOTOR CONTACTOR (DELTA)
KM3.6	3	CONTATTORE MOTORE POMPA GASOLIO	LIGHT OIL PUMP MOTOR CONTACTOR
KT3.5	3	TEMPORIZZATORE STELLA/TRIANGOLO	STAR/DELTA DELAYED RELAY
LAF	4	LAMPADA SEGNALAZIONE ALTA FIAMMA BRUCIATORE	BURNER IN HIGH FLAME INDICATOR LIGHT
LB	3	LAMPADA SEGNALAZIONE BLOCCO BRUCIATORE	INDICATOR LIGHT FOR BURNER LOCK-OUT
LBF	4	LAMPADA SEGNALAZIONE BASSA FIAMMA BRUCIATORE	BURNER IN LOW FLAME INDICATOR LIGHT
LEVG	4	LAMPADA SEGNALAZIONE APERTURA [EVG]	INDICATOR LIGHT FOR OPENING OF ELECTRO-VALVE [EVG]
LEVP	3	LAMPADA SEGNALAZIONE APERTURA [EVP]	INDICATOR LIGHT FOR OPENING OF ELECTRO-VALVE [EVP]
LPGP	2	LAMPADA SEGNALAZIONE PRESSOSTATO GAS PILOTA	INDICATOR LIGHT FOR PRESENCE OF GAS IN THE PILOT NETWORK
LS	2	LAMPADA SEGNALAZIONE SOSTA BRUCIATORE	INDICATOR LIGHT FOR BURNER STAND-BY
LT	2	LAMPADA SEGNALAZIONE BLOCCO TERMICO MOTORE VENTILATORE	INDICATOR LIGHT FOR FAN MOTOR OVERLOAD THERMAL CUTOUT
LTA	3	LAMPADA SEGNALAZIONE TRASFORMATORE DI ACCENSIONE	IGNITION TRANSFORMER INDICATOR LIGHT
LTP	2	LAMPADA SEGNALAZIONE BLOCCO TERMICO POMPA	INDICATOR LIGHT FOR PUMP OVERLOAD TRIPPED
MP	1	MOTORE POMPA GASOLIO	LIGHT OIL PUMP MOTOR
MV	1	MOTORE VENTILATORE	FAN MOTOR
PA	2	PRESSOSTATO ARIA	AIR PRESSURE SWITCH
PGP	2	PRESSOSTATO PILOTA GAS	PILOT MINIMUM GAS PRESSURE SWITCH
POMAX	2	PRESSOSTATO DI MASSIMA PRESSIONE OLIO (OPTIONAL)	MAXIMUM OIL PRESSURE SWITCH (OPTIONAL)
PS	2	PULSANTE SBLOCCO FIAMMA	LOCK-OUT RESET BUTTON
SIEMENS LAL 2.25	2	APPARECCHIATURA CONTROLLO FIAMMA	CONTROL BOX
SQM10	4	SERVOCOMANDO SERRANDA ARIA	AIR DAMPER ACTUATOR
ST	2	SERIE TERMOSTATI/PRESSOSTATI	SERIES OF THERMOSTATS OR PRESSURE SWITCHES
TA	3	TRASFORMATORE DI ACCENSIONE	IGNITION TRANSFORMER
TAB	4	TERMOSTATO/PRESSOSTATO ALTA-BASSA FIAMMA	HIGH-LOW THERMOSTAT/PRESSURE SWITCHES
TP	1	TERMICO MOTORE POMPA	PUMP MOTOR THERMAL
TV	1	TERMICO MOTORE VENTILATORE	FAN MOTOR THERMAL
[SQM40.265A]	4	SERVOCOMANDO SERRANDA ARIA (ALTERNATIVO)	AIR DAMPER ACTUATOR (ALTERNATIVE)

Data	05/07/2011	PREC.	FOGLIO
Revisione	02	5	6
Dis. N.	12 - 0186	SEGUE	TOTALE
		/	6