



BURNERS
BRULEURS
BRENNER
QUEMADORES
BRUCIATORI

MANUAL OF - INSTALLATION - OPERATION - MAINTENANCE

LIGHT OIL BURNERS

G4 - G6
G10 - G18

SINGLE STAGE

M03964CC Rel. 2.2 02/24

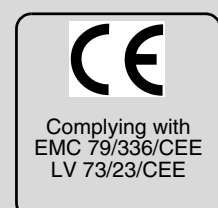

WARNINGS

THIS MANUAL IS SUPPLIED AS AN INTEGRAL AND ESSENTIAL PART OF THE PRODUCT AND MUST BE DELIVERED TO THE USER.

INFORMATION INCLUDED IN THIS SECTION ARE DEDICATED BOTH TO THE USER AND TO PERSONNEL FOLLOWING PRODUCT INSTALLATION AND MAINTENANCE.

THE USER WILL FIND FURTHER INFORMATION ABOUT OPERATING AND USE RESTRICTIONS, IN THE SECOND SECTION OF THIS MANUAL. WE HIGHLY RECOMMEND TO READ IT.

CAREFULLY KEEP THIS MANUAL FOR FUTURE REFERENCE.

1) GENERAL INTRODUCTION

- The equipment must be installed in compliance with the regulations in force, following the manufacturer's instructions, by qualified personnel.
- Qualified personnel means those having technical knowledge in the field of components for civil or industrial heating systems, sanitary hot water generation and particularly service centres authorised by the manufacturer.
- Improper installation may cause injury to people and animals, or damage to property, for which the manufacturer cannot be held liable.
- Remove all packaging material and inspect the equipment for integrity.

In case of any doubt, do not use the unit - contact the supplier. The packaging materials (wooden crate, nails, fastening devices, plastic bags, foamed polystyrene, etc), should not be left within the reach of children, as they may prove harmful.

- Before any cleaning or servicing operation, disconnect the unit from the mains by turning the master switch OFF, and/or through the cut-out devices that are provided.
- Make sure that inlet or exhaust grilles are unobstructed.
- In case of breakdown and/or defective unit operation, disconnect the unit. Make no attempt to repair the unit or take any direct action.

Contact qualified personnel only.

Units shall be repaired exclusively by a servicing centre, duly authorised by the manufacturer, with original spare parts.

Failure to comply with the above instructions is likely to impair the unit's safety.

To ensure equipment efficiency and proper operation, it is essential that maintenance operations are performed by qualified personnel at regular intervals, following the manufacturer's instructions.

- When a decision is made to discontinue the use of the equipment, those parts likely to constitute sources of danger shall be made harmless.
- In case the equipment is to be sold or transferred to another user, or in case the original user should move and leave the unit behind, make sure that these instructions accompany the equipment at all times so that they can be consulted by the new owner and/or the installer.
- For all the units that have been modified or have options fitted then original accessory equipment only shall be used.
- This unit shall be employed exclusively for the use for which it is meant. Any other use shall be considered as improper and, therefore, dangerous.

The manufacturer shall not be held liable, by agreement or otherwise, for damages resulting from improper installation, use and failure to comply with the instructions supplied by the manufacturer.

2) SPECIAL INSTRUCTIONS FOR BURNERS

- The burner should be installed in a suitable room, with ventilation openings complying with the requirements of the regulations in force, and sufficient for good combustion.
- Only burners designed according to the regulations in force should be used.
- This burner should be employed exclusively for the use for which it was designed.
- Before connecting the burner, make sure that the unit rating is the same as delivery mains (electricity, gas oil, or other fuel).
- Observe caution with hot burner components. These are, usually, near to the flame and the fuel pre-heating system, they become hot during the unit operation and will remain hot for some time after the burner has stopped.

When the decision is made to discontinue the use of the burner, the user shall have qualified personnel carry out the following operations:

- a) Remove the power supply by disconnecting the power cord from the mains.
- b) Disconnect the fuel supply by means of the hand-operated shut-off valve and remove the control handwheels from their spindles.

Special warnings

- Make sure that the burner has, on installation, been firmly secured to the appliance, so that the flame is generated inside the appliance firebox.
- Before the burner is started and, thereafter, at least once a year, have qualified personnel perform the following operations:
 - a) set the burner fuel flow rate depending on the heat input of the appliance;
 - b) set the flow rate of the combustion-supporting air to obtain a combustion efficiency level at least equal to the lower level required by the regulations in force;
 - c) check the unit operation for proper combustion, to avoid any harmful or polluting unburnt gases in excess of the limits permitted by the regulations in force;
 - d) make sure that control and safety devices are operating properly;
 - e) make sure that exhaust ducts intended to discharge the products of combustion are operating properly;
 - f) on completion of setting and adjustment operations, make sure that all mechanical locking devices of controls have been duly tightened;
 - g) make sure that a copy of the burner use and maintenance instructions is available in the boiler room.
- In case of repeated burner shut-downs, do not continue re-setting the unit manually. Contact qualified personnel to take care of such defects.
- The unit shall be operated and serviced by qualified personnel only, in compliance with the regulations in force.

3) GENERAL INSTRUCTIONS DEPENDING ON FUEL USED

3a) ELECTRICAL CONNECTION

- For safety reasons the unit must be efficiently earthed and installed as required by current safety regulations.
- It is vital that all safety requirements are met. In case of any doubt, ask for an accurate inspection of electricians by qualified personnel, since the manufacturer cannot be held liable for damages that may be caused by failure to correctly earth the equipment.
- Qualified personnel must inspect the system to make sure that it is adequate to take the maximum power used by the equipment shown on the equipment rating plate. In particular, make sure that the system cable cross section is adequate for the power absorbed by the unit.
- No adaptors, multiple outlet sockets and/or extension cables are permitted to connect the unit to the electric mains.
- An omnipolar switch shall be provided for connection to mains, as required by the current safety regulations.
- The use of any power-operated component implies observance of a few basic rules, for example:
 - u do not touch the unit with wet or damp parts of the body and/or with bare feet;
 - u do not pull electric cables;
 - u do not leave the equipment exposed to weather (rain, sun, etc.) unless expressly required to do so;
 - u do not allow children or inexperienced persons to use equipment;
- The unit input cable shall not be replaced by the user. In case of damage to the cable, switch off the unit and contact qualified personnel to replace. When the unit is out of use for some time the electric switch supplying all the power-driven components in the system (i.e. pumps, burner, etc.) should be switched off.

3b) FIRING WITH GAS, LIGHT OIL OR OTHER FUELS

GENERAL

- The burner shall be installed by qualified personnel and in compliance with regulations and provisions in force; wrong installation can cause injuries to people and animals, or damage to property, for which the manufacturer cannot be held liable.
- Before installation, it is recommended that all the fuel supply system pipes be carefully cleaned inside, to remove foreign matter that might impair the burner operation.
- Before the burner is commissioned, qualified personnel should inspect the following:
 - a) the fuel supply system, for proper sealing;
 - b) the fuel flow rate, to make sure that it has been set based on the firing rate required of the burner;
 - c) the burner firing system, to make sure that it is supplied for the designed fuel type;
 - d) the fuel supply pressure, to make sure that it is included in the range shown on the rating plate;
 - e) the fuel supply system, to make sure that the system dimensions are adequate to the burner firing rate, and that the system is equipped with all the safety and control devices required by the regulations in force.
- When the burner is to remain idle for some time, the fuel supply tap or taps should be closed.

SPECIAL INSTRUCTIONS FOR USING GAS

Have qualified personnel inspect the installation to ensure that:

- a) the gas delivery line and train are in compliance with the regulations and provisions in force;
 - b) all gas connections are tight;
 - c) the boiler room ventilation openings are such that they ensure the air supply flow required by the current regulations, and in any case are sufficient for proper combustion.
- Do not use gas pipes to earth electrical equipment.
 - Never leave the burner connected when not in use. Always shut the gas valve off.
 - In case of prolonged absence of the user, the main gas delivery valve to the burner should be shut off.

Precautions if you can smell gas

- a) do not operate electric switches, the telephone, or any other item likely to generate sparks;
 - b) immediately open doors and windows to create an air flow to purge the room;
 - c) close the gas valves;
 - d) contact qualified personnel.
- Do not obstruct the ventilation openings of the room where gas appliances are installed, to avoid dangerous conditions such as the development of toxic or explosive mixtures.

TECHNICAL DATA

BURNERS SERIE POLYMATIC		G4	G4....P
Output	min. kcal/h	18.000	12.000
	max. kcal/h	35.000	35.000
	min. kW	21	14
	max. kW	41	41
Oil rate	Kg/h min.	1.8	1.2
	Kg/h max.	3.5	3.5
Fuel		light oil	light oil
Power supply\		220÷400 V	
Motor 2800 g/m' (50 Hz)	W	75	75
Motor 3400 g/m' (60 Hz)	W	100	100
Current absorption		0.65	0.65
Total power consumption (50 Hz)	W	375	475
Total power consumption (60 Hz)	W	400	500
Weight Kg ca.		12.5	12.5
Operation		single stage	single stage
Pre-heater		no	yes

BURNERS SERIE POLYMATIC		G6	G10	G18
Output	min. kcal/h	25.000	50.000	90.000
	max. kcal/h	60.000	100.000	180.000
	min. kW	29	58	105
	max. kW	70	116	209
Oil rate	Kg/h min.	2.5	5	9
	Kg/h max.	6	10	18
Fuel		light oil	light oil	light oil
Power supply		220÷400 V		
Motor 2800 g/m' (50 Hz)	W	100	150	200
Motor 3400 g/m' (60 Hz)	W	150	200	250
Current absorption		0.75	1.1	1.4
Total power consumption (50 Hz)	W	400	450	500
Total power consumption (60 Hz)	W	450	500	550
Weight Kg ca.		14.5	16	17
Operation		single stage	single stage	single stage
Pre-heater		no	no	no

BURNER MODEL IDENTIFICATION

Burners are identified by burner type and model. Burner model identification is described as follow:

Type: G4	Model:	G-	TN.	S.	*	A.	P
(1)		(2)	(3)	(4)	(5)	(6)	(7)
(1) BURNER TYPE					G - Light oil		
(2) FUEL					TN - Single stage		
(3) OPERATION	Available versions				S - Standard		
(4) BLAST TUBE LENGHT (See overall dimensions)	Available versions				L - Long		
(5) DESTINATION COUNTRY					* - See data plate		
(6) VERSIONS					A - Standard		
					B - Bakery oven		
					C - Bakery oven with external air inlet		
					D - Chef		
					F - Chef special		
					N - Internal air setting (G4)		
					S - Internal air setting without connector (G4)		
					Y - Special		
					Z - Without housing		
(7) EQUIPMENT					M - Air damper jack		
					P - Pre-heater		

OVERALL DIMENSIONS

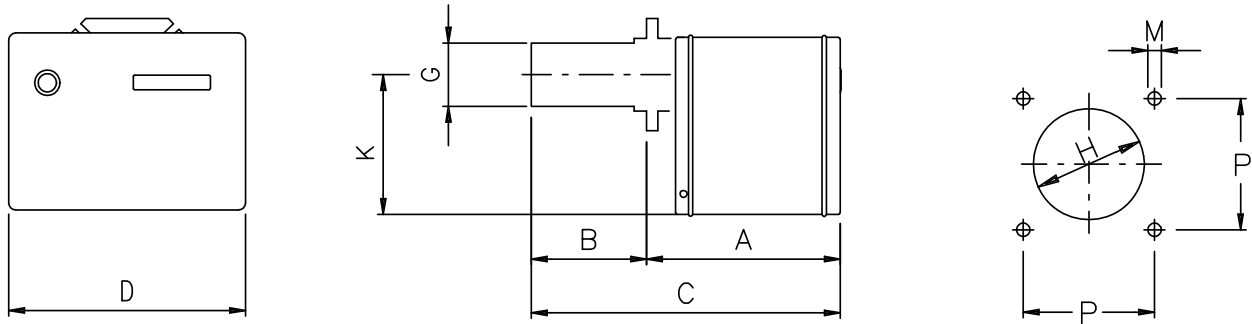

Fig. 1

SERIE POLYMATIC

	A	B	BL	C	CL	D	E	G	K	H	P	M
G4 - G4P	230	35 ÷ 55	35 ÷ 130	285	360	295	230	80	175	90	85 ÷ 134	M8

SERIE MINIFLAM

	A	B	BL	C	CL	D	E	G	K	H	P	M
G6	290	35 ÷ 60	170	350	-	310	230	80	190	90	85 ÷ 134	M8
G10	275	80	200	355	475	340	255	90	230	125	121 ÷ 134	M8
G18	275	80	200	355	475	340	255	115	230	125	121 ÷ 134	M8

PERFORMANCE CURVES

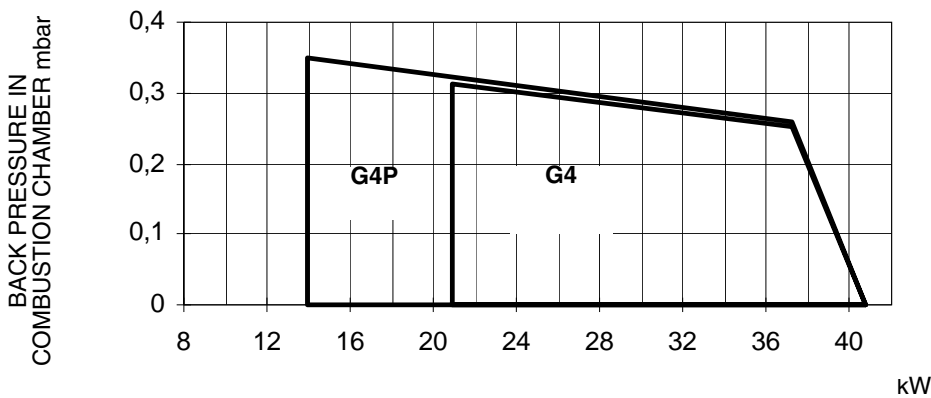

Fig. 2

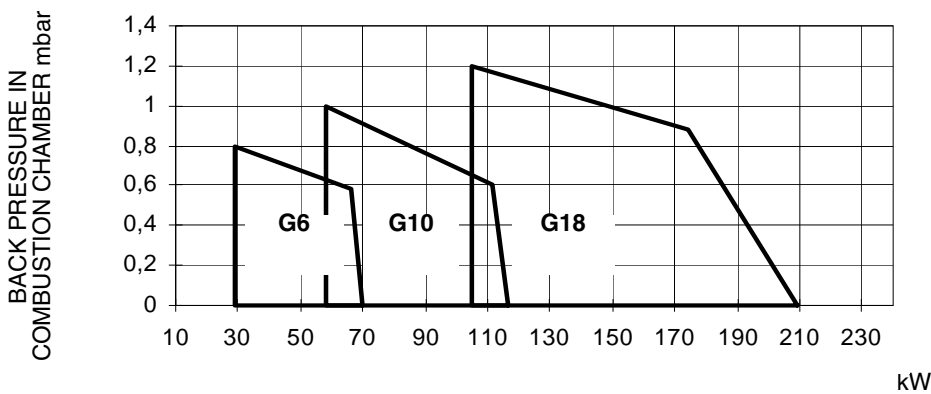

Fig. 3

MOUNTINGS AND CONNECTIONS

Packing

The burners are despatched in cardboard packages of dimensions::

G4..S	330 - 320 - 300 mm (H x W x D)
G4..L	390 - 320 - 300 mm (H x W x D)
G6	360 - 300 - 450 mm (H x W x D)
G10..S - G18..S	420 - 350 - 420 mm (H x W x D)
G10..L - G18..L	420 - 350 - 620 mm (H x W x D)

Packing cases of this type are affected by humidity and are not suitable for stacking.

The following are placed in each packing case:

- 1 burner;
- 2 flexible light oil tubes;
- 1 filter;
- 1 gasket to be inserted between the burner and the boiler;
- 1 this manual.

When disposing of the burner packing and if the packing is scrapped follow the procedures laid down in the current legislation regarding the disposal of materials.

Fitting the burner to the boiler

Fix the flange of the burner to the boiler as shown in Fig. 4.

This allow a correct inclination towards the combustion chamber. If necessary, after fitting the burner to the boiler, seal the space between the blast tube and the refractory lining with appropriate insulating material (ceramic fibre cord or refractory cement).

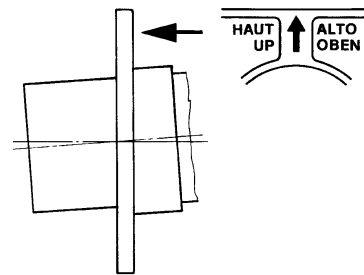

Fig. 4

Electrical connections diagram

- Remove the burner's housing;
- make the electrical connections following the schemes in Fig. 5a and Fig. 5b;
- refit the burner's housing.

Only G4 G-.TN.x.xx.S.x

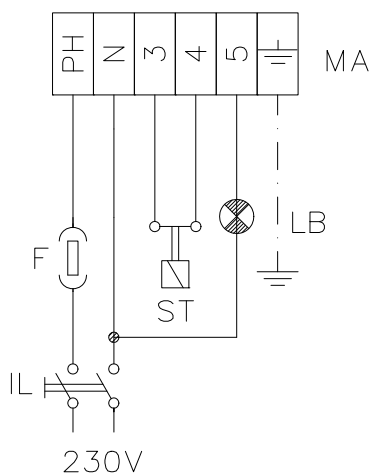

Fig. 5a

All models excluded G4 G-.TN.x.xx.S.x

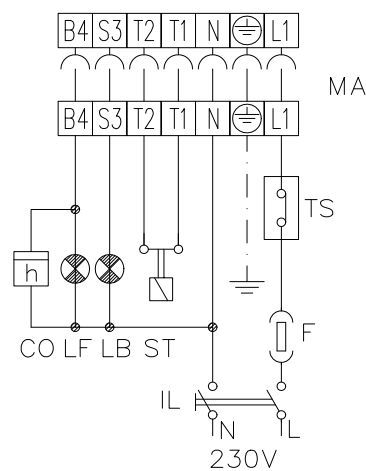

Fig. 5b

RESPECT THE BASIC SAFETY RULES. MAKE SURE OF THE CONNECTION TO THE EARTHING SYSTEM. DO NOT REVERSE THE PHASE AND NEUTRAL CONNECTIONS. FIT A DIFFERENTIAL THERMAL MAGNET SWITCH ADEQUATE FOR CONNECTION TO THE MAINS.

LIGHT OIL TUBING INSTALLATION DIAGRAM

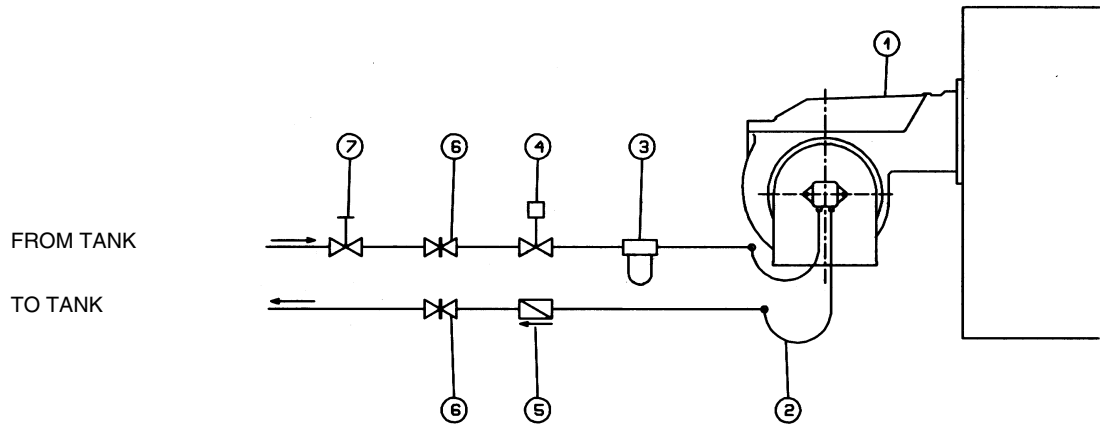

Fig. 6

Key

- 1 Burner
- 2 Flexible hoses (supplied)
- 3 Light oil filter (supplied)
- 4 Automatic interception device
- 5 One-way valve
- 6 Gate valve
- 7 Quick-closing gate valve (not in the same room as tank or boiler)

Determining diameter of light oil supply pipes

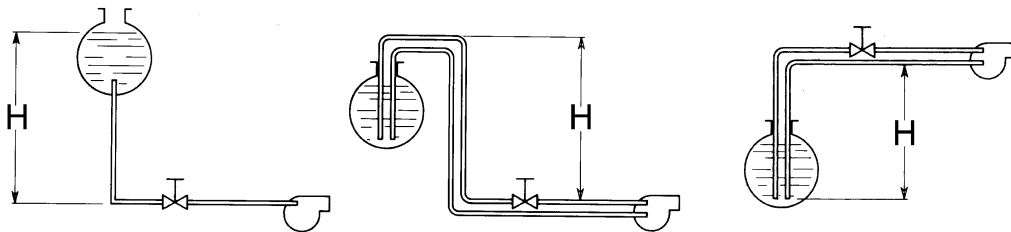

Fig. 7

Tab. 1

H (m)	L (m)		
	Ø 6	Ø 8	Ø 10
0	41	100	100
0.5	70	100	100
1	100	100	100
1.5	100	100	100
2	100	100	100
2.5	100	100	100
3	100	100	100
3.5	100	100	100
4	100	100	100
4.5	100	100	100
5	100	100	100

Tab. 2

H (m)	L (m)			
	Ø 6	Ø 8	Ø 10	Ø 12
0	19	77	100	100
1	24	90	100	100
2	30	100	100	100
3	34	100	100	100
4	39	100	100	100
5	44	100	100	100
6	48	100	100	100
7	52	100	100	100
8	56	100	100	100
9	55	100	100	100
10	51	100	100	100

Tab. 3

H (m)	L (m)			
	Ø 6	Ø 8	Ø 10	Ø 12
0	18	73	100	100
0.5	15	66	100	100
1	13	59	100	100
1.5	10	52	100	100
2	7	44	100	100
2.5	5	44	100	100
2.5	-	37	100	100
3	-	30	85	100
3.5	-	23	68	100
4	-	-	-	100
4.5	-	-	-	-

Single pipe system

The burners leave the factory ready for a 2 pipes supply system.

It is however possible to transform them for a single pipe supply system (advisable in the case of a gravity feed system).

See appendix for details of the operations to be carried out.

SETTINGS

Oil rate adjustment

The oil rate is set choosing a properly sized nozzle and adjusting the feeding pressure to the nozzle, in the pump (see principle diagram of the light oil ring in Fig. 8). To choose the proper nozzle refer to Tab. 4; to set the pump pressure see technical data on Page 9 and Page 10. For further informations on oil pumps see the appendix.

Starting the pump

Before carrying out the adjustment it is necessary to start up the oil pump proceeding as follows:

- before operating the burner, make sure that the return pipe to the tank is not obstructed. Any obstruction would cause the pump seal to break.
- Start the burner, light up the photoresistance after opening the solenoid valve and let the air escape from the pressure gauge connection;

Key

- EV Oil solenoid valve
- M Manometer
- P Pump

Fig. 8

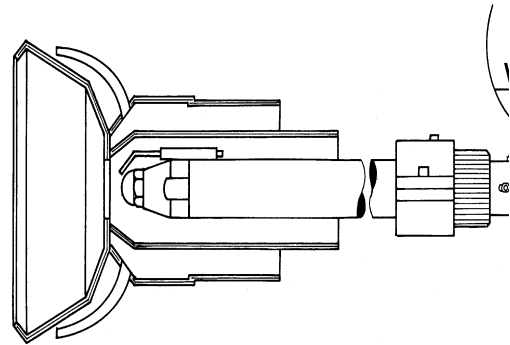

Tab. 4 - Choice of the oil nozzle

G.P.H.	Kg/h	10 bar		Kg/h	12 bar		Kg/h	14 bar	
		kcal/h	kW		kcal/h	kW		kcal/h	kW
0.40	1.52	15.500	18	1.67	17.100	19.8	1.80	18.400	21.4
0.50	1.90	19.400	22.5	2.08	21.200	24.6	2.25	22.900	26.6
0.60	2.28	23.250	27	2.50	25.500	29.6	2.70	27.500	31.9
0.65	2.47	25.200	29.2	2.71	27.600	32	2.92	29.800	34.6
0.75	2.85	29.100	33.8	3.12	31.800	36.9	2.7	34.400	40
0.85	3.23	33.000	38.3	3.54	36.100	41.9	3.82	39.000	45.3
1.00	3.80	38.800	45	4.16	42.400	49.2	4.50	45.800	53.2
1.10	4.18	42.600	49.5	4.58	46.700	54.2	4.95	50.500	58.6
1.20	4.56	46.500	54	5.00	51.000	59.2	5.40	55.500	64.4
1.25	4.75	48.400	56.2	5.20	53.00	61.5	5.60	57.100	66.3
1.35	5.13	52.300	60.7	5.62	57.000	66.2	6.07	62.000	72
1.50	5.70	58.000	67.3	6.24	63.600	73.9	6.75	69.000	80.1
1.65	6.27	64.000	74.4	6.86	69.900	81.3	7.42	76.000	88.3
1.75	6.65	68.000	79	7.28	74.200	86.3	7.87	80.000	93
2.00	7.60	77.500	90.1	8.32	84.800	98.6	8.99	92.000	106.9
2.25	8.55	87.200	101.4	9.36	95.400	111	10.12	103.000	119.7
2.50	9.50	97.000	112.8	10.40	106.000	123.3	11.24	115.000	133.7
3.00	11.40	116.000	134.9	12.48	127.200	148	13.49	137.000	159.3
3.50	13.30	135.800	157.9	14.56	148.750	173	15.74	160.700	186.9
4.00	15.20	155.200	180.4	16.65	170.000	197.7	17.99	183.700	213.6
4.50	17.10	174.600	203	18.73	191.250	222.4	20.24	206.650	240.3

OIL PUMPS

SERIE POLYMATIC

Pump Suntec AS47 A

Viscosity	2 - 12 mm ² /s (cSt)
Oil temperature	0 - 60 °C in the pump
Inlet pressure	2 bar max.
Return pressure	2 bar max.
Suction height	0,45 bar max. to avoid air from oil separation
Rotation speed	3600 rpm max.

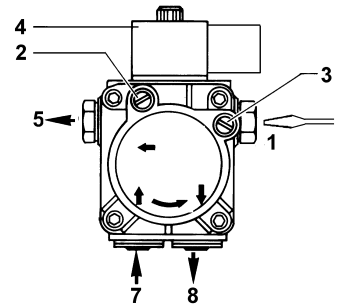

Fig. 9

Pump DELTA VM1RL2

Viscosity	2 - 50 mm ² /s (cSt)
Oil temperature	0 - 60 °C in the pump
Inlet pressure	2 bar max.
Return pressure	2 bar max.
Suction height	0,5 bar max. to avoid air from oil separation
Rotation speed	3500 rpm max.

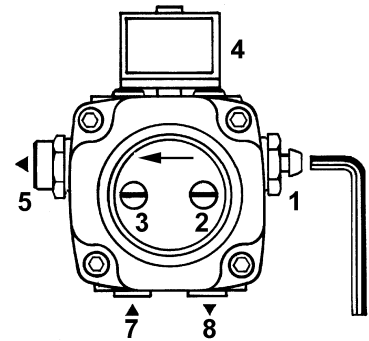

Fig. 10

Pump DANFOSS BFP21R3

Viscosity	1.3 - 12 mm ² /s (cSt)
Oil temperature	70 °C in the pump
Inlet pressure	2 bar max.
Return pressure	2 bar max.
Suction height	0,35 bar max. to avoid air from oil separation
Rotation speed	3600 rpm max.

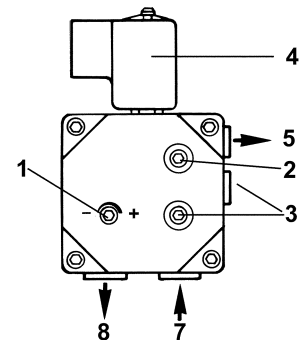

Fig. 11

SERIE MINIFLAM

Pump Suntec AS47 C

Viscosity	2 - 12 mm ² /s (cSt)
Oil temperature	0 - 60 °C in the pump
Inlet pressure	2 bar max.
Return pressure	2 bar max.
Suction height	0,45 bar max. to avoid air from oil separation
Rotation speed	3600 rpm max.

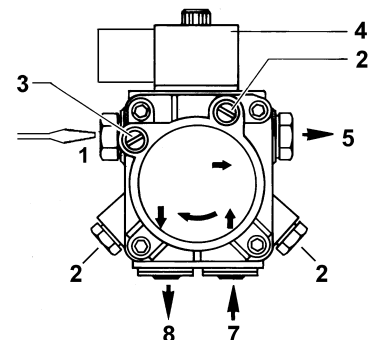

Fig. 12

Key

- 1 Pressure setting
- 2 Manometer
- 3 Vacuumeter
- 4 Solenoid valve
- 5 Nozzle
- 7 Inlet
- 8 Return

Pump DELTA VM1LR2

Viscosity	2 - 50 mm ² /s (cSt)
Oil temperature	0 - 60 °C in the pump
Inlet pressure	2 bar max.
Return pressure	2 bar max.
Suction height	0,5 bar max. to avoid air separation from oil
Rotation speed	3500 rpm max.

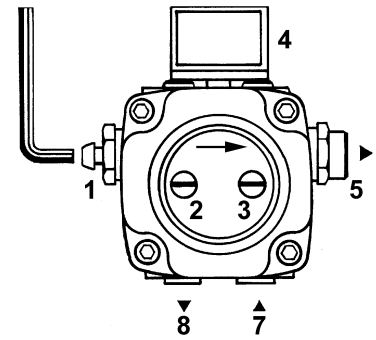

Fig. 13

Pump DANFOSS BFP21L3

Viscosity	1.3 - 12 mm ² /s (cSt)
Oil temperature	70 °C in the pump
Inlet pressure	2 bar max
Return pressure	2 bar max
Suction height	0,35 bar max. to avoid air separation from oil
Rotation speed	3600 rpm max.

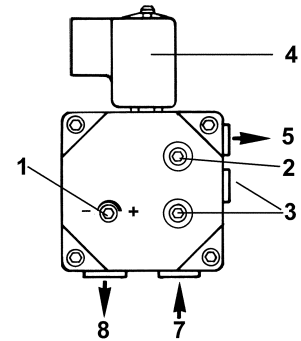

Fig. 14

Key

- 1 Pressure setting
- 2 Manometer
- 3 Vacuometer
- 4 Solenoid valve
- 5 Nozzle
- 7 Inlet
- 8 Return

AIR RATE SETTING

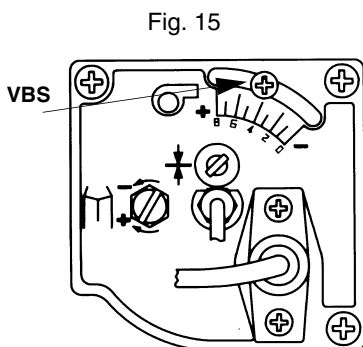

Fig. 15

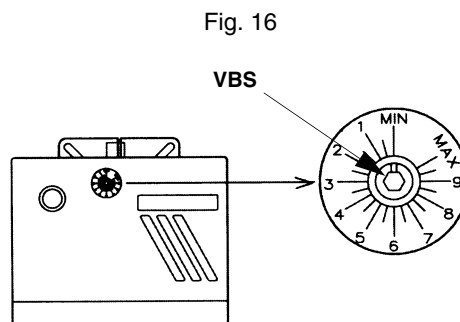

Fig. 16

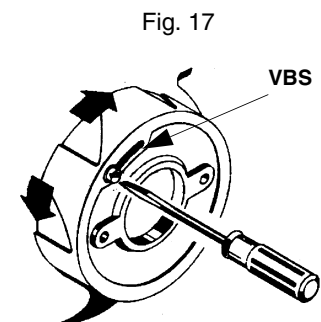

Fig. 17

Type G4 mod. G-.TN...N.x and G-.TN...S (internal air setting)

- Slacken the screw VBS.
- The air rate is set moving the screw VBS through the slot.
- At the end of settings tight the screw VBS.

Type G4 mod. G-.TN.x*.A.x (external air setting)

Set the air rate rotating the screw VBS.

Type G6 - G10 - G18

- Slacken the screw VBS and rotate manually the air damper as needed.
- At the end of settings tight the screw VBS.

COMBUSTION HEAD ADJUSTMENT

Rotate the screw VBS clockwise or anticlockwise, by means of a screwdriver, depending on the need to develop the minimum or maximum output. In case of replace of the combustion head, set to default value to the position indicated in Fig. 21a and Fig. 21b, respect to the nozzle end.

Type G4 - G4....P

Fig. 18

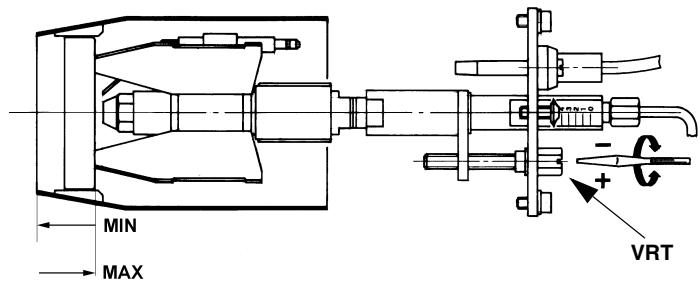

Type G6

Fig. 19

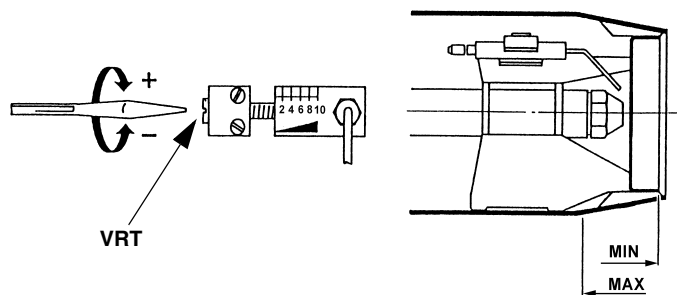

Type G10 - G18

Rotate the screw VRT clockwise or anticlockwise, by means of a screwdriver, depending on the need to develop the minimum or maximum output. In case of replace of the combustion head, set to default value to the position indicated in Fig. 20 (and Tab. 9), respect to the nozzle end.

Fig. 20

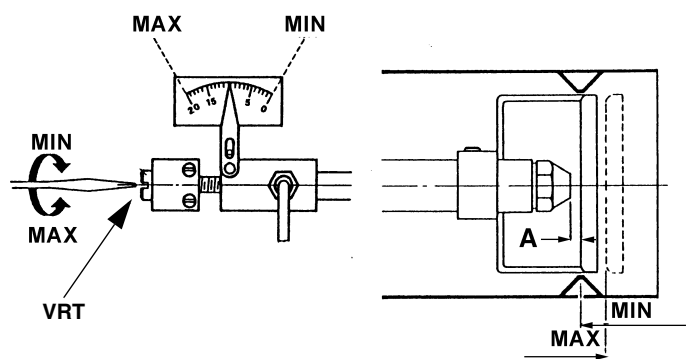

COMBUSTION SETTING

Tab. 5 -Type G4

NOZZLE G.P.H. 60°	PUMP PRESSURE BAR	OIL RATE Kg/h +10%	POSITION OF THE COMB. HEAD INDEX	SETTING OF THE AIR DAMPER INDEX
0.40	10 - 12	1.52 - 1.66	1 - 1.5	3.5 - 3.5
0.50	10 - 12	1.90 - 2.08	1.5 - 1.5	4.5 - 5
0.60	10 - 12	2.28 - 2.50	2.5 - 2.5	5 - 6
0.65	10 - 12	2.47 - 2.70	2.5 - 3	6.5 - 8
0.75	10 - 12	2.85 - 3.12	4.5 - 5	6.5 - 8.5

Tab. 5a - Type G4 with pre-heater

NOZZLE G.P.H. 60°	PUMP PRESSURE BAR	OIL RATE Kg/h +10%	POSITION OF THE COMB. HEAD INDEX	SETTING OF THE AIR DAMPER INDEX
0.40	10 - 12	1.25 - 1.36	1.5 - 1.5	3 - 3.5
0.50	10 - 12	1.70 - 1.86	2 - 2	3.5 - 4
0.60	10 - 12	2.22 - 2.41	2 - 2	5.5 - 7
0.65	10 - 12	2.31 - 2.46	2.5 - 3	5 - 5.5
0.75	10 - 12	2.76 - 3	3.5 - 3.5	5.5 - 7

Tab. 6 - Type G6

NOZZLE G.P.H. 60°	PUMP PRESSURE BAR	OIL RATE Kg/h +10%	POSITION OF THE COMB. HEAD INDEX	SETTING OF THE AIR DAMPER INDEX
0.60	10 - 12	2.35 - 2.60	1.5 - 1.5	4 - 4
0.75	10 - 12	3.00 - 3.30	2 - 2.5	5.2 - 6
0.85	10 - 12	3.40 - 3.85	3 - 4	5.5 - 6
1.00	10 - 12	3.90 - 4.20	3.5 - 4.5	7 - 7
1.10	10 - 12	4.10 - 4.50	4 - 6	7 - 7
1.20	10 - 12	4.70 - 5.20	6.5 - 7.5	7.5 - 8
1.35	10 - 12	5.40 - 5.80	9 - 10	8 - 8

Tab. 7 - Type G10

NOZZLE G.P.H. 60°	PUMP PRESSURE BAR	OIL RATE Kg/h +10%	POSITION OF THE COMB. HEAD INDEX	SETTING OF THE AIR DAMPER INDEX
1.20	10 - 12	4.80 - 5.10	0 - 0	1.5 - 1.8
1.35	10 - 12	5.35 - 5.80	1 - 1	2 - 2.3
1.50	10 - 12	5.95 - 6.60	2 - 2	2.3 - 2.7
1.75	10 - 12	7.00 - 7.40	3 - 5	3 - 3.5
2.00	10 - 12	7.80 - 8.60	6 - 8	3.7 - 4
2.25	10 - 12	8.90 - 9.60	8 - 8.5	4 - 5
2.50	10 - 12	9.40 - 10.50	8.5 - 10.5	5 - 6

Tab. 8 -Type G18

NOZZLE G.P.H. 60°	PUMP PRESSURE BAR	OIL RATE Kg/h +10%	POSITION OF THE COMB. HEAD INDEX	SETTING OF THE AIR DAMPER INDEX
2.25	10 - 12	8.95 - 9.40	5 - 5.5	4 - 5
2.50	10 - 12	9.50 - 10.40	5.5 - 7	5 - 5
2.75	10 - 12	10.70 - 11.75	7 - 9.5	5 - 5
3.00	10 - 12	11.80 - 12.85	10 - 11	5 - 5
3.50	10 - 12	13.85 - 15.00	12 - 14	6 - 7
4.00	10 - 12	15.35 - 16.65	15 - 17	7 - 8
4.50	10 - 12	17.00 - 18.00	18 - 20	8 - 8

LIMITATIONS OF USE

THE BURNER IS AN APPLIANCE DESIGNED AND CONSTRUCTED TO OPERATE ONLY AFTER BEING CORRECTLY CONNECTED TO A HEAT GENERATOR (E.G. BOILER, HOT AIR GENERATOR, FURNACE, ETC.), ANY OTHER USE IS TO BE CONSIDERED IMPROPER AND THEREFORE DANGEROUS.

THE USER MUST GUARANTEE THE CORRECT FITTING OF THE APPLIANCE, ENTRUSTING THE INSTALLATION OF IT TO QUALIFIED PERSONNEL AND HAVING THE FIRST COMMISSIONING OF IT CARRIED OUT BY A SERVICE CENTRE AUTHORISED BY THE COMPANY MANUFACTURING THE BURNER.

A FUNDAMENTAL FACTOR IN THIS RESPECT IS THE ELECTRICAL CONNECTION TO THE GENERATOR'S CONTROL AND SAFETY UNITS (CONTROL THERMOSTAT, SAFETY, ETC.) WHICH GUARANTEES CORRECT AND SAFE FUNCTIONING OF THE BURNER.

THEREFORE, ANY OPERATION OF THE APPLIANCE MUST BE PREVENTED WHICH DEPARTS FROM THE INSTALLATION OPERATIONS OR WHICH HAPPENS AFTER TOTAL OR PARTIAL TAMPERING WITH THESE (E.G. DISCONNECTION, EVEN PARTIAL, OF THE ELECTRICAL LEADS, OPENING THE GENERATOR DOOR, DISMANTLING OF PART OF THE BURNER).

NEVER OPEN OR DISMANTLE ANY COMPONENT OF THE MACHINE.

OPERATE ONLY THE MAIN SWITCH, WHICH THROUGH ITS EASY ACCESSIBILITY AND RAPIDITY OF OPERATION ALSO FUNCTIONS AS AN EMERGENCY SWITCH, AND ON THE RESET BUTTON.

IN THE EVENT OF REPEATED LOCKOUTS, DO NOT PERSIST WITH THE RESET BUTTON AND CONTACT QUALIFIED PERSONNEL WHO WILL PROCEED TO ELIMINATE THE MALFUNCTION.

WARNING: DURING NORMAL OPERATION THE PARTS OF THE BURNER NEAREST TO THE GENERATOR (COUPLING FLANGE) CAN BECOME VERY HOT, AVOID TOUCHING THEM SO AS NOT TO GET BURNT

OPERATION

- Turn on the burner by means of the main switch on the boiler electrical board.
- Check the flame monitor device is not locked out and if necessary press the reset button (through the hole in the burner casing).
- Check that the series of thermostats (or pressure switches) enable the burner to operate.
- The ignition cycle starts: the control device starts the fan motor and, meanwhile, feeds the ignition transformer.
- When the prepurge has been completed, the oil solenoid valve are energized and the burner is ignited.
- The ignition transformer remains on for any seconds after the ignition (post-ignition time). At the end of such time it is de-energized.

At least once a year, carry out the following maintenance procedures. Where servicing is on a seasonal basis it is recommended for the end of the heating season; routine servicing should be carried out every 6 months if the burner operates the year long.

WARNING: All operations on the burner must be carried out with the power disconnected!

PERIODICAL SERVICING

- Clean and examine the oil filter cartridge and replace it if necessary.
- Examine the condition of the oil flexible hoses and check for possible leaks.
- Clean and examine the filter inside the oil pump (see instructions in the Appendix).
- Dismantle, examine and clean the combustion head and when reassembling be carefully to respect the measures shown in Tab. 9.
- Examine the ignition electrodes and their ceramic insulators, adjust and replace if necessary (see Fig. 21a and Fig. 21b).
- Dismantle and clean the oil nozzle (important: use solvents for cleaning, not metal utensils), and at the end of the maintenance procedures, after replacing the burner, turn it on and check the shape of the flame; if in doubt replace the nozzle. If the burner is used intensively it is recommended to replace the nozzle(s) at the start of the operating season.
- Examine and carefully clean the flame detector photoelectric cell and replace it if necessary. If in doubt, light the burner and check the detection circuit following the procedure illustrated in Fig. 22.

Correct position of electrodes and combustion head

- Prepare a stable surface where lean the burner during maintenance.
- To gain access to the combustion head and to the nozzles, slacken the screw VB on the blast tube and remove it from the part that remains fixed to the boiler.
- To guarantee a good ignition, respect the measures indicated in Tab. 9.
- Be sure to tight the screw that fix the electrodes group, before reassembly the burner.

Tab. 9

	NOZZLE	A	B	C	D
G4 - G4 P	60°	4	3	2 ÷ 3	6
	45°	6	3	2 ÷ 3	6
G6	60°	5	3	4	6
	45°	8	4	4	6
G10 - G18	60°	6	4	4	6
	45°	10	5	4	6

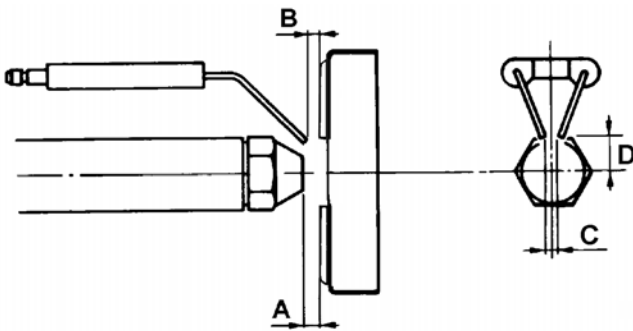

Fig. 21a - Burners G4 and G6

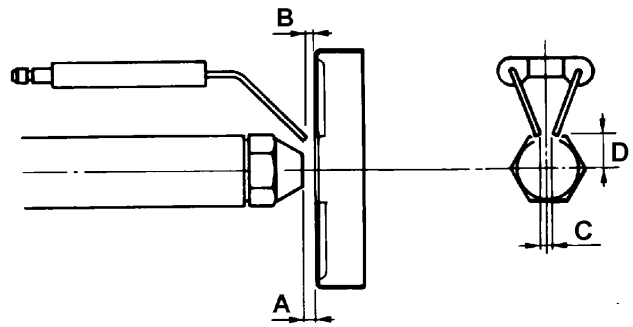

Fig. 21b - Burners G10 and G18

Check the detection current

See the diagram in Fig. 22, to measure the detection current. If the signal doesn't suit the suggested value, verify the electric terminals, the cleaning of the combustion head and the position of the photoelectric cell and replace it if required.

- Minimum current intensity with flame: 65 µA
- Maximum current intensity without flame: 5 µA
- Maximum possible current intensity with flame: 200 µA

Fig. 22

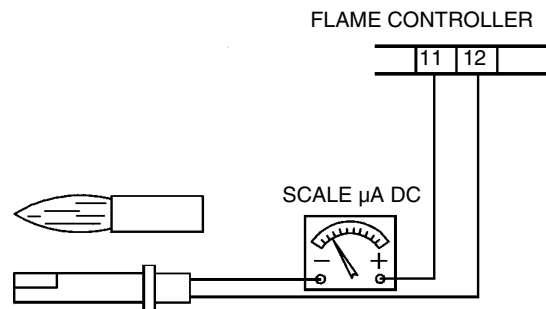

ELECTRICAL DIAGRAMS

Electrical diagram cod. 01-361 Rev. 2 - Burners G4 - G6 - G10 - G18 Standard versions

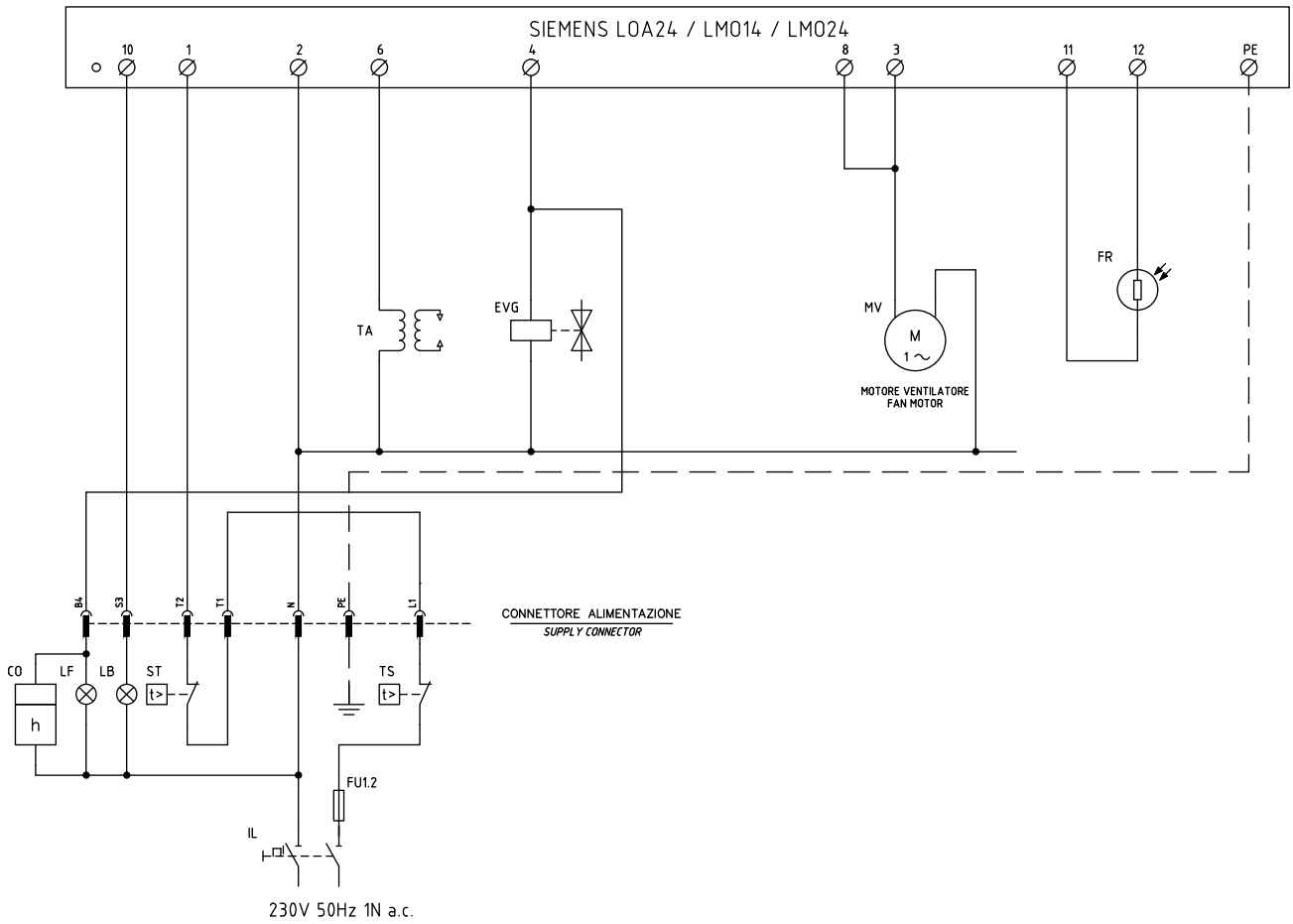

Key

CO	Time counter
EVG	Light oil solenoid valve
F	Fuse
FR	Photoresistor
IL	Line switch
L1	Phase
LF	Burner in operation signaling lamp
LB	Burner lockout signaling lamp
LOA24/LMO24	Flame control device SIEMENS
MA	Burner power supply terminal board
MV	Fan motor
N	Neutral
ST	Thermostats or pressure switches
TA	Ignition transformer
TS	Thermostat / pressure switch on boiler

ATTENTION

- 1 - Power supply 230V 50Hz 2N a.c.
- 2 - Don't reverse phase with neutral
- 3 - Ensure the burner is properly hearthed

Electrical diagram cod. 01-142/2 - Burners G4 - G6 - G10 - G18
Versions with internal air setting without connector

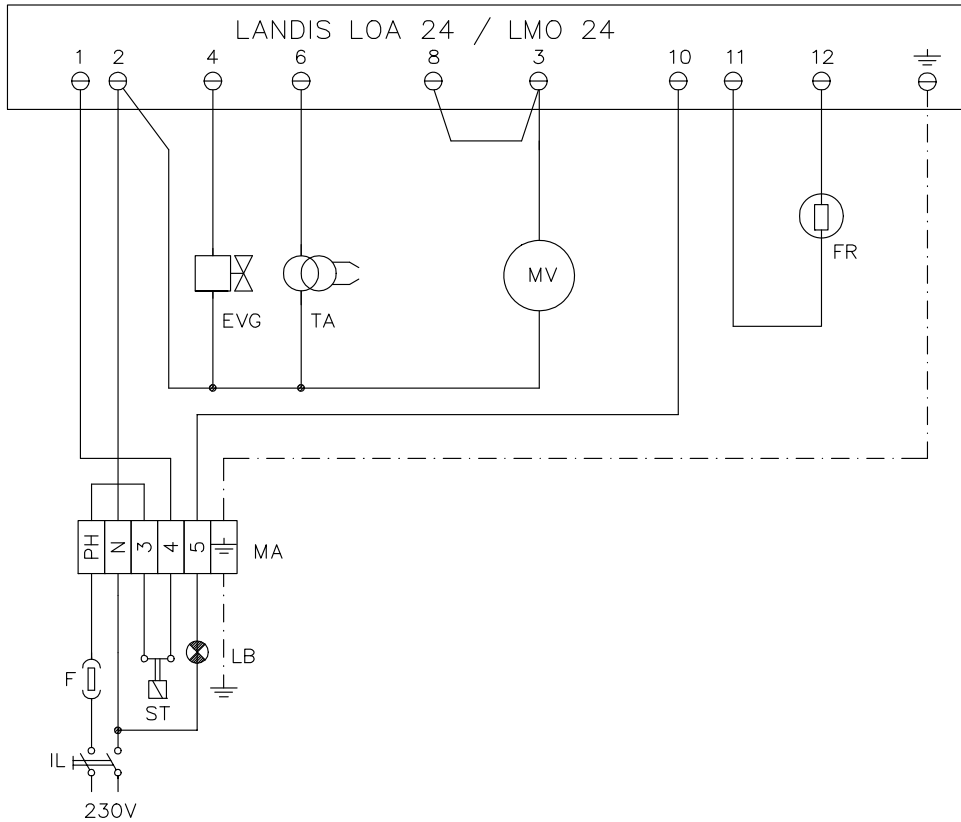

Key	
EVG	Oil solenoid valve
F	Fuse
FR	Photoresistor
IL	Line switch
LB	Burner lockout signaling lamp
LOA24/LMO24	Flame control device LANDIS
MA	Burner power supply terminal board
MV	Fan motor
N	Neutral
PH	Phase
ST	Thermostats or pressure switches
TA	Ignition transformer

ATTENTION

- 1 - Power supply 230V 50Hz 2N a.c.
- 2 - Don't reverse phase with neutral
- 3 - Ensure the burner is properly hearthed

Electrical diagram cod. 01-362 Rev. 2 - Burners fitted with pre-heater

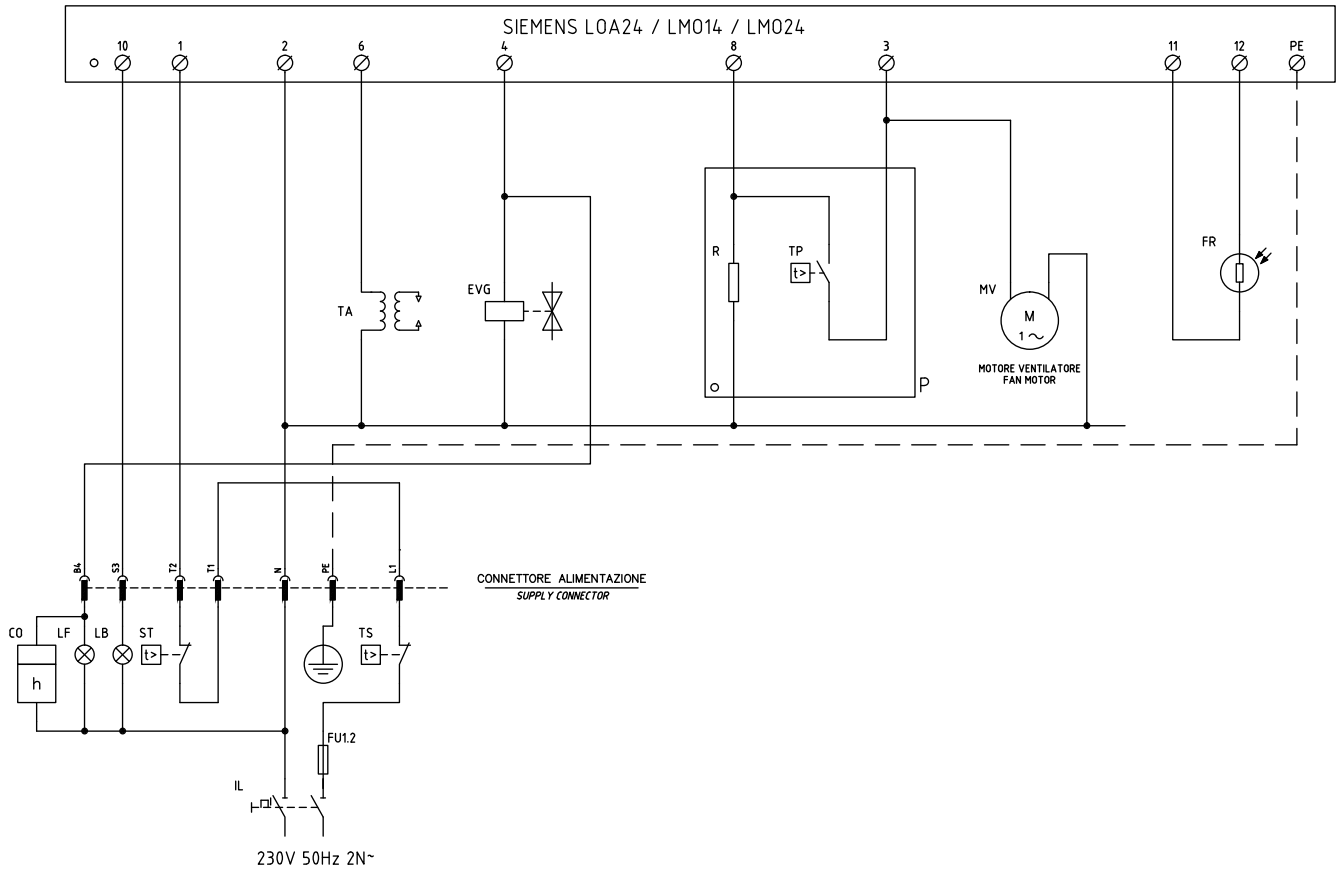

Key

CO	Time counter
EVG	Oil solenoid valve
F	Fuse
FR	Photoresistor
IL	Line switch
L1	Phase
LB	Burner lockout signaling light
LF	Burner operation signaling light
LOA24/LMO24	Flame control device SIEMENS
MA	Burner power supply terminal board
MV	Fan motor
N	Neutral
P	Oil pre-heater
R	Pre-heater resistor
ST	Thermostats or pressure switches
TA	Ignition transformer
TP	Pre-heater thermostat
TS	Thermostat / pressure switch on boiler

ATTENTION

- 1 - Power supply 230V 50Hz 2N a.c.
- 2 - Don't reverse phase with neutral
- 3 - Ensure the burner is properly hearthed

SPARE PARTS
Burners type G4

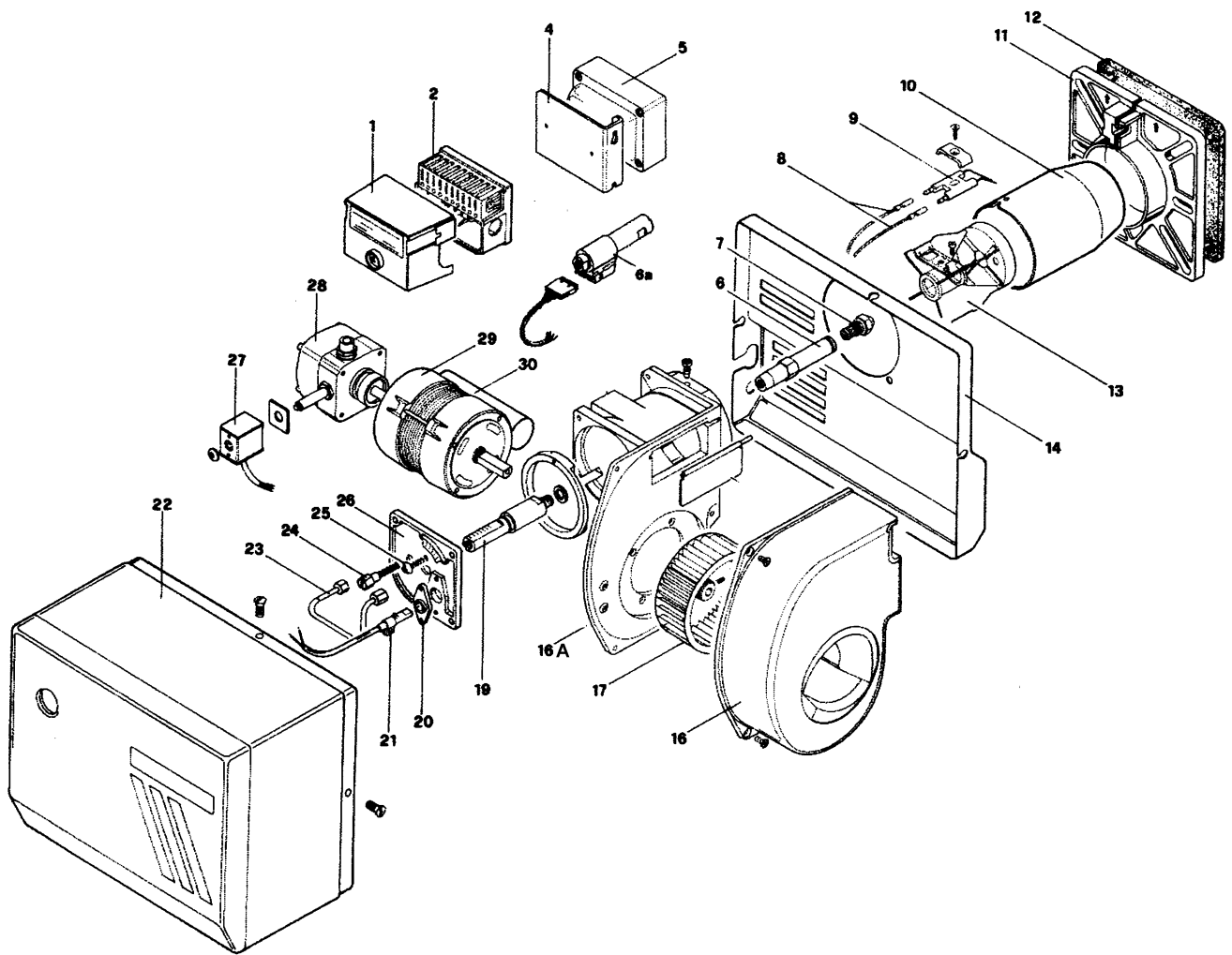

POS.	DESCRIPTION	G4	G4...P
1	FLAME CONTROL DEVICE LOA24	2020445	2020445
2	SOCKET FOR LOA24	2030409	2030409
4	BRACKET FOR LOA24	2430062	2430062
5	TRANSFORMER COFI E820	2170117	2170117
6	NOZZLE HOLDER - STANDARD	2850037	2850037
6	NOZZLE HOLDER - LONG	2850059	2850059
	EXTENSION FOR PRE-HEATER	2850109	2850109
6A	PRE-HEATER	2850040	2850040
7	NOZZLE	261...	261...
8	IGNITION CABLE - STANDARD	6050119	6050119
8A	IGNITION CABLE - LONG	6050122	6050122
9	IGNITION ELECTRODE	2080232	2080232
10	BLAST TUBE - STANDARD	30900E3	30900E3
10A	BLAST TUBE - LONG	30900E4	30900E4
11	FLANGE	2100025	2100025
12	GASKET	2110027	2110027
13	COMBUSTION HEAD	3060180	3060180
14	BOTTOM	3190101	2010115
16	BURNER HOUSING - RIGHT	2050267	1010022
16A	BURNER HOUSING - LEFT	2050268	2050263
17	FAN	2150020	2150020
19	NOZZLE HOLDER EXTENSION	2850113	2850113
20	PHOTORESISTOR SOCKET	---	---
21	PHOTORESISTOR LANDIS QRB1B	2510008	2510008
22	FAIRING	3010043	3010032
23	PIPE FOR VM1 RL2	2220141	2220141
23	PIPE FOR AS47A	2220141	2220141
23	PIPE FOR BFP21R3	2220141	2220141
24	HEAD ADJUSTING SCREW	2320023	2320023
25	INDEX SCREW	2350095	2350095
26	ATOMIZER FLANGE	2100065	2100037
27	COIL FOR DELTA VM1 RL2	2580406	2580406
27	COIL FOR SUNTEC AS47A	2580402	2580402
27	COIL FOR DANFOSS BFP21 R3	2580701	2580701
28	PUMP DELTA VM1RL2	2590012	2590012
28	PUMP SUNTEC AS47A	2590130	2590130
28	PUMP DANFOSS BFP21R3	2590309	2590309
29	MOTOR SIMEL 75W	2180052	2180052
29	MOTOR AEG 75W	2180701	2180701
30	CAPACITOR	6030013	6030013
	OIL FLEXIBLE HOSES	2340055	2340055
	OIL FILTER	2090001	2090001

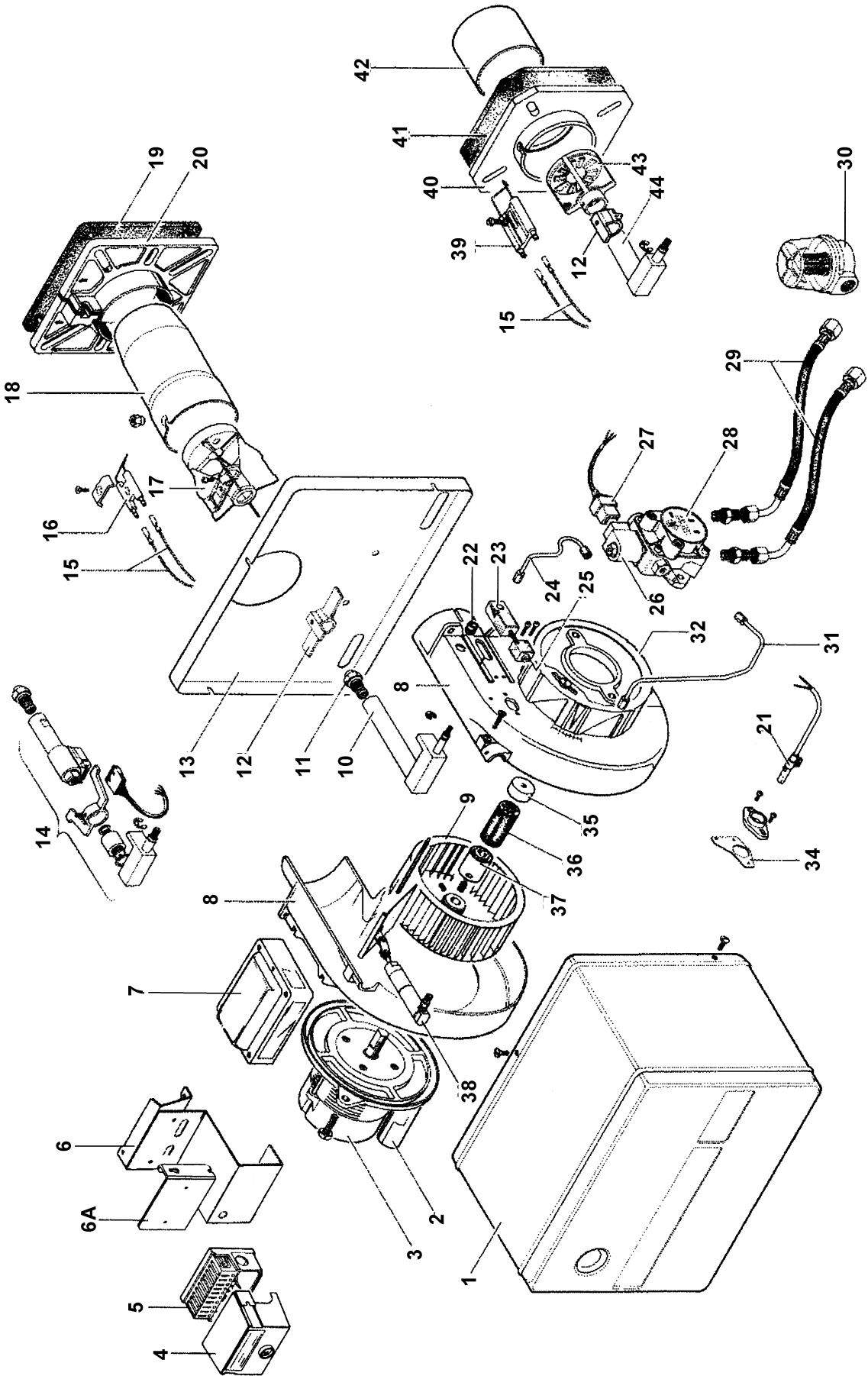

POS.	DESCRIPTION	G6	G10	G18
1	FAIRING	3010018	3010019	3010019
2	CAPACITOR	6030003	6030005	6030005
3	MOTOR SIMEL	2180013	2180005	2180014
3	MOTOR AEG	2180702	2180703	---
4	FLAME CONTROL DEVICE LOA24	2020445	2020445	2020445
5	SOCKET FOR LOA24	2030409	2030409	2030409
6	BRACKET FOR LOA24	2430004	2430004	2430004
6A	SPACER FOR LOA24	2060002	2060002	2060002
7	TRANSFORMER COFI 1020	2170106	2170106	2170106
8	COMPLETE HOUSING	2050239	2050239	2050239
8	COMPLETE HOUSING (VERSION W. AIR DAMPER JACK)	2050237	2050236	2050236
9	FAN	2150003	2150004	2150004
10	NOZZLE HOLDER ASSEMBLY	3020047	---	---
10	NOZZLE HOLDER ASSEMBLY (VERSION BL)	3020069	---	---
11	NOZZLE	26100..	26100..	26100..
12	NOZZLE HOLDER	2280032	2280006	2280006
13	BOTTOM	2010112	2010102	2010102
14	PRE-HEATER KIT DANFOSS	---	---	---
15	IGNITION CABLE	6050119	6050122	6050122
16	IGNITION ELECTRODE	2080232	---	---
17	COMBUSTION HEAD	3060139	---	---
18	BLAST TUBE - STANDARD	30900A2	---	---
18A	BLAST TUBE - LONG	30900A1	---	---
19	GASKET	2110027	---	---
20	FLANGE	2100025	---	---
21	PHOTORESISTOR LANDIS QRB1B	2510008	2510008	2510008
22	PHOTORESISTOR HOLDER	2030222	---	---
23	MOVING BLOCK	2320012	2320012	2320012
24	PIPE FOR AS47C	2220113	2220125	2220125
24	PIPE FOR VM1RL2	2220145	2220146	2220146
24	PIPE FOR BFP21L3	2220113	2220125	2220125
25	HEAD ADJUSTING SCREW	2320011	2320011	2320011
26	COIL FOR SUNTEC AS47C	2580402	2580402	2580402
26	COIL FOR DELTA VM1RL2	2580406	2580406	2580406
26	COIL FOR DANFOSS BFP21L3	2580701	2580701	2580701
27	CONNECTOR FOR SUNTEC AS47C	6200008	6200008	6200008
27	CONNECTOR FOR DANFOSS BFP21L3	6200009	6200009	6200009
28	PUMP DELTA VM1RL2	2590014	2590014	2590014
28	PUMP SUNTEC AS47C	2590011	2590011	2590011
28	PUMP DANFOSS BF021L3	2590308	2590308	2590308
28	PUMP DELTA VM1RL2-2P (VERSION W. AIR DAMPER JACK)	2590019	2590019	2590019
	FLANGE FOR DELTA PUMP	2690015	2690015	2690015
	FLANGE FOR DANFOSS PUMP	2590503	2590503	2590503
29	FLEXIBLE HOSES	2340001	2340001	2340001
30	FILTER	2090001	2090001	2090001
31	PIPE (PUMP'S JACK)	2220115	2220116	2220116
32	AIR DAMPER	1010704	1010002	1010002
34	PHOTORES. SOCKET (VERSION WITHOUT JACK)	2030219	2030219	2030219
34	PHOTORES. SOCKET (VERSION WITH JACK)	2030227	2030220	2030220
35	JOINT LP	2540002	2540002	2540002
36	COUPLING FOR JOINT	2540007	2540007	2540007
37	JOINT LV	2540003	2540003	2540003
38	COMPLETE JACK	2330010	2330015	2330015
39	IGNITION ELECTRODE	---	2080203	2080203
40	FLANGE	---	2100007	2100011
41	GASKET	---	2110031	2110031
42	BLAST TUBE - STANDARD	---	3090005	3090006
42	BLAST TUBE - LONG	---	3090008	3090009
43	COMBUSTION HEAD	---	3060102	3060103
44	NOZZLE HOLDER ASSEMBLY - STANDARD	---	3020016	3020016
44	NOZZLE HOLDER ASSEMBLY - LONG	---	3020020	3020020

APPENDIX: COMPONENTS CHARACTERISTICS

LANDIS OIL BURNERS AUTOMATIC CONTROLLER LOA24	23
SIEMENS OIL BURNERS AUTOMATIC CONTROLLER SIEMENS LMO14 - LMO24 - LMO44	25
DELTA VM PUMPS	28
SUNTEC PUMPS AS 47 - 57 - 67	29
NOTES FOR USE AND MAINTENANCE OF FUEL PUMPS	30

LANDIS OIL BURNERS AUTOMATIC CONTROLLER LOA24

Use

LOA... safety devices are intended for use solely with QRB... photore-sistors, for lighting and controlling low capacity forced air light oil burn-ers with max. capacity 30 kg/h in accordance with standard DIN 4787.

The One or two flames are lit through electrical connections with or without post-ignition.

To replace LAI... AND LAB.. WITH LOA...

LOA... models can be used as replacement for LAI... and LAB.. con-trollers by means of the adapter KF8819 and without the need to change the electrical wiring. Because the LOA is smaller in dimen-sions, when it is used with the adapter the external dimensions are almost identical, which means that there is no need to move the reset button.

Performance

The controllers just need plugging in, so they can be mounted in almost any position: on the burner, on the electrical panel or on the control panel. The casing is made of robust heat-resistant plastic and contains:

- the thermic programmer operating a multiple switch control system with ambient temperature compensator
- flame signal amplifier with flame relay
- warning light indicating lockout and associated sealed reset but-ton.

The plug-in socket, also made of robust heat-resistant plastic, con-tains the 12 terminals and also:

- 3 neutral terminals, ready wired up to terminal 2
- 4 earth terminals for earthing the burner
- 2 supplementary terminals numbered "31" and "32".

The socket has two openings at the bottom for the leads; 5 others with threaded connection for cable holders PG11 or 3/4UNP for non-metallic sleeves are located on a mobile stuffing box, one on either side and 3 on the front.

There are two flexible metal tongues on the sides of the socket for mounting.

To dismantle it only requires gentle pressure with a screw driver in the slot of the mounting guide. The base dimensions of the socket are exactly the same as for types LAB/LAI and there is no difference in the diameter of the reset button, the two mounting screws and the flange of the burner earth.

Safety at low voltage levels

Safety devices against any reduction in the mains voltage operate on a special electronic circuit which, in the event of the power supply fall-ing below 165V~, stops the burner switching on without releasing the fuel and locks out the apparatus.

Wiring diagram of the programme

To ensure correct wiring it is essential to observe local standards and follow the instructions of the burner manufacturer with regard to assembly and start-up.

Program's legend:

- Controller output signals
- ▨ Required input signals
- A' Burner start up with light oil pre-heater OH
- A Burner start-up without light oil pre-heater
- B Flame lit
- C Normal operation
- D Normal stop through R
- tw Oil pre-heating time until operational all clear given through contact OW
- t1 Pre-purge time
- t3 Pre-ignition time
- t2 Safety time
- t3n Post-ignition time
- t4 Interval between the flame lighting and energising of solenoid 2a at terminal 5

Internal layout

- AL Optical alarm
- BV. Fuel valve
- EK Reset button
- FR Flame relay
- fr Flame relay contacts
- FS Flame alight signal
- G Burner motor
- K Flame relay anchor to delay the tzl command in the event of a premature flame signal or endorse it where the signal is correct.
- OH light oil pre-heater
- OW Operational all-clear contact
- QRB Photo-resistant cell (flame detector)
- R Thermostat or pressure switch
- TZ Thermo-electric programmer (bimetal system)
- tz.. TZ contacts
- V Flame signal amplifier
- W Safety thermostat or pressure switch
- Z Ignition transformer

The above are safety devices!

To tamper with them in any way may have unforeseeable conse-quences!

Do not open them!

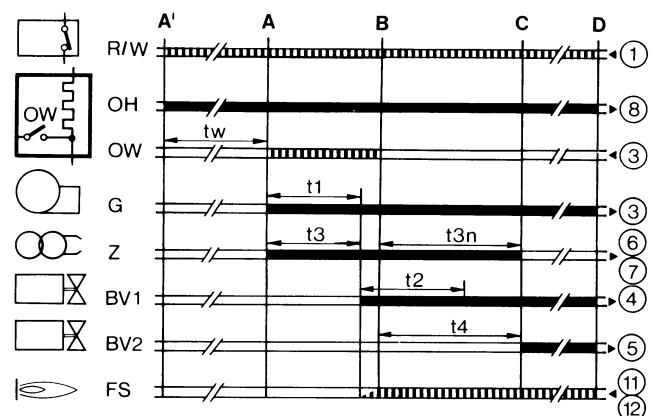
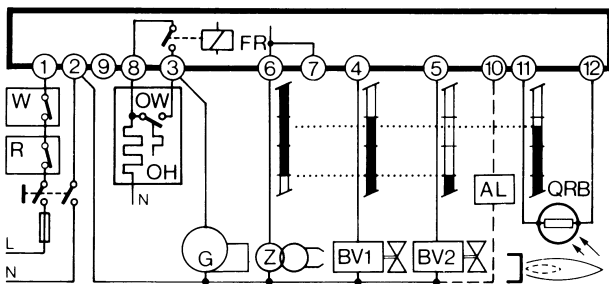

Technical characteristics

Voltage	220V -15%..240V+10% or 100V -15%...110V+10%
Frequency	50...60Hz +/- 6%
External fuse	max.10A slow action
Contact flow:	
- terminal 1	5A
- terminal 3	5A (incl.capacity absorbed by motor and pre-heater)
Terminal flow:	
terminals 4, 5 &10	1A
terminals 6&7	2A
terminal 8	5A
Absorbed cap	3VA
Protection	IP40
Permitted temp:	
operational	-20...+60°C
transport & storage	-50...+60°C
Emplacement	any
Mass (weight)	controller 180g, socket 50g, AGK accessories 12 g.

Commands in the event of operational interference

Stray light/premature ignition

During pre-purge and/or pre-ignition there should be no flamesignal. If there is a flame signal, eg from premature ignition due to a faulty solenoid, external light, short circuit in the photoresisto or wiring, malfunction in the flame signal amplifier, etc., at the end of pre-purge and safety time the controller locks out the burner and stops the fuel flow even during safety time.

Absence of flame

If there is no flame at the end of safety time the controller locks out immediately.

Absence of flame during operation

If there is no flame during operation the controller cuts off the supply of fuel and automatically initiates a fresh start-up programme: at the end of t4 the start-up programme ends.

Whenever there is a safety stop, terminals 3-8 and 11 are de-energi- sed in less than 1 second; at the same time a remote lockout signal is transmitted through terminal 10. The controller can be reset after c. 50 seconds.

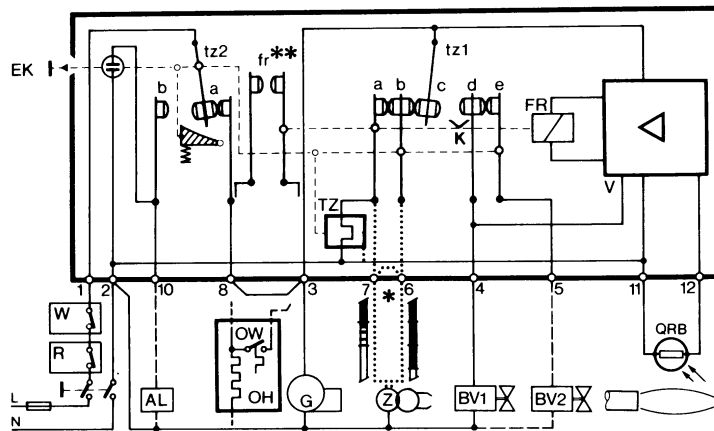

SIEMENS OIL BURNERS AUTOMATIC CONTROLLER SIEMENS LMO14 - LMO24 - LMO44

The LMO... burner controls are designed for the start-up and supervision of single- or 2-stage forced draught oil burners in intermittent operation. Yellow-burning flames are supervised with photoresistive detectors QRB..., blue-burning flames with blue-flame detectors QRC...

In terms of housing dimensions, electrical connections and flame detectors, the LMO... are identical to the LOA... oil burner controls.

Preconditions for startup

- Burner control is reset
- All contacts in the line are closed
- No undervoltage
- Flame detector is darkened, no extraneous light

Undervoltage

- Safety shut-down in the operating position takes place should the mains voltage drop below about AC 165 V
- Restart is initiated when the mains voltage exceeds about AC 175 V

Time supervision oil pre-heater

If the oil pre-heater's release contact does not close within 10 minutes, the burner control will initiate lock-out.

Controlled intermittent operation

After no more than 24 hours of continuous operation, the burner control will initiate an automatic safety shut-down followed by a restart.

Control sequence in the event of fault

If lock-out occurs, the outputs for the fuel valves and the ignition will immediately be deactivated (< 1 second).

Cause	Response
After a mains failure	Restart
After voltage has fallen below the undervoltage threshold	Restart
In the event of a premature, faulty flame signal during «t1»	Lock-out at the end of «t1»
In the event of a premature, faulty flame signal during «tw»	Prevention of start-up, lock-out after no more than 40 seconds
If the burner does not ignite during «TSA»	Lock-out at the end of TSA
In the event the flame is lost during operation	Max. 3 repetitions, followed by lock-out
Oil pre-heater's release contact does not close within 10 min.	Lock-out

Lock-out

In the event of lock-out, the LMO... remains locked (lock-out cannot be changed), and the red signal lamp will light up. This status is also maintained in the case of a mains failure.

Resetting the burner

Whenever lock-out occurs, the burner control can immediately be reset. To do this, keep control the lock-out reset button depressed for about 1 second (< 3 seconds).

Ignition program with LMO24.113A2

If the flame is lost during «TSA», the burner will be reignited, but not later than at the end of «TSAmax.». This means that several ignition attempts can be made during TSA (refer to «Program sequence»).

Limitation of repetitions

If the flame is lost during operation, a maximum of 3 repetitions can be made. If the flame is lost for the 4th time during operation, the burner will initiate lock-out. The repetition count is restarted each time controlled switching on by «R-W-SB» takes place.

Operation

Lock-out reset button «EK...» is the key operating element for resetting the burner control and for activating / deactivating the diagnostic functions.



The multicolour «LED» is the key indicating element for both visual diagnosis and interface diagnosis.

- s Red
- l Yellow
- o Green

Colour code table

Status	Colour code	Colour
Oil pre-heater heats, waiting time «tw»	llllllllll	Yellow
Ignition phase, ignition controlled	lmlmlmlml	Yellow-off
Operation, flame o.k.	oooooooooooo	Green
Operation, flame not o.k.	omomomomomo	Green-off
Undervoltage	lslslslslsl	Yellow-red
Fault, alarm	ssssssssss	Red
Output of fault code (refer to Fault code table)	smsmsmsmsm	Red-off
Extraneous light prior to burner start-up	osososososo	Green-red
Interface diagnosis	ssssssssssss	Red flicker light

Key

- m Off
- l Yellow
- o Green
- s Red

Diagnosis of cause of fault

After lock-out, the red fault signal lamp remains steady on.

In that condition, the visual diagnosis of the cause of fault according to the error code table can be activated by pressing the lock-out reset button for more than 3 seconds.

Error code table

Blink code	Possible cause
2 blinks **	No establishment of flame at the end of TSA <ul style="list-style-type: none"> ● Faulty or soiled fuel valves ● Faulty or soiled flame detector ● Poor adjustment of burner, no fuel ● Faulty ignition
3 blinks ***	Free
4 blinks ****	Extraneous light on burner startup
5 blinks *****	Free
6 blinks ****	Free
7 blinks ****	Too many losses of flme during operation (limitattion og the number of repetitions) <ul style="list-style-type: none"> ● Faulty or soiled fuel valves ● Faulty or soiled flame detector ● Poor adjustment of burner
8 blinks ****	Time supervision oil pre-heater
9 blinks ****	Free
10 blinks ****	Wiring error or internal error, output contacts

During the time the cause of fault is diagnosed, the control outputs are deactivated.

- Burner remains shut down

- Fault status signal «AL» at terminal 10 is activated

The diagnosis of the cause of fault is quit and the burner switched on again by resetting the burner control.

Press lock-out reset button for about 1 second (< 3 seconds).

Connection diagram and internal diagram

LMO14

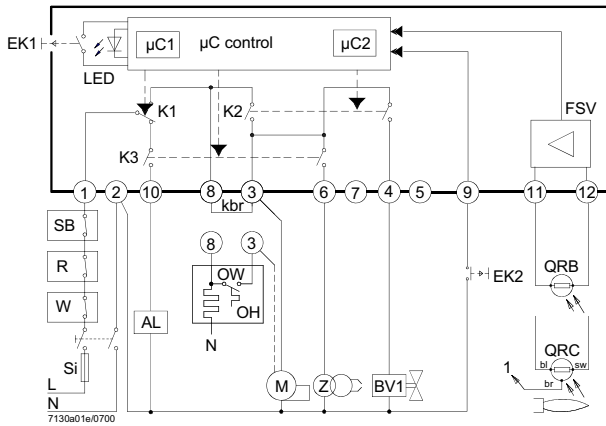

LMO24 - LMO44

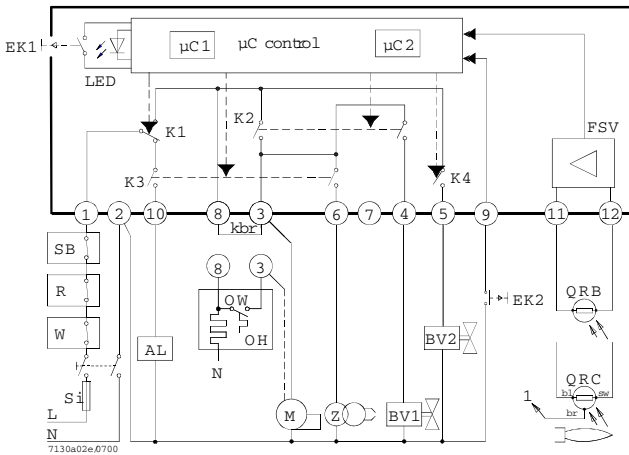

Control sequence

LMO14

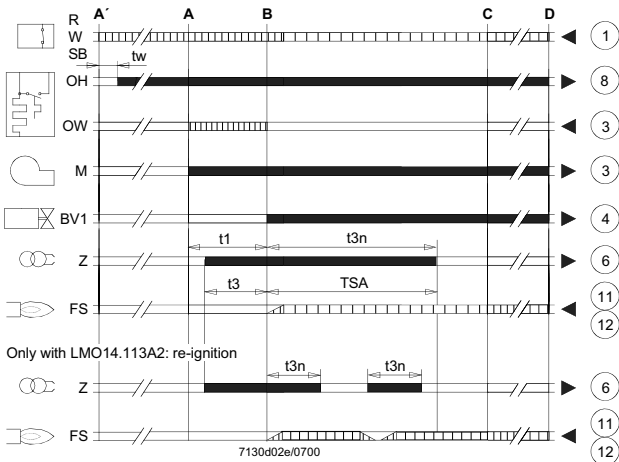

LMO24 - LMO44

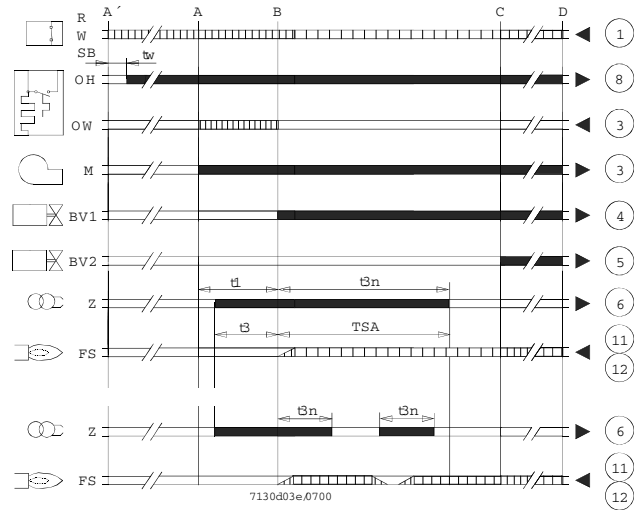

Key

- AL Alarm device
- kbr... Cable link (required only when no oil pre-heater is used)
- BV... Fuel valve
- EK1 Lock-out reset button
- EK2 Remote lock-out reset button
- FS Flame signal
- FSV Flame signal amplifier
- K... Contacts of control relay
- LED 3-colour signal lamps
- M Burner motor
- OW Release contact of oil pre-heater
- t1 Pre-purge time
- t3 Pre-ignition time
- t3n Post-ignition time
- A' Beginning of start-up sequence with burners using an oil pre-heater
- A Beginning of start-up sequence with burners using no oil pre-heater
- Controller output signals
- Required input signals
- OH Oil pre-heater
- QRB Photoresistive detector
- QRC Blue-flame detector
- bl = blue
- br = brown
- sw = black
- R Control thermostat or pressurestat
- SB Safety limit thermostat
- Si External primary fuse
- W Limit thermostat or pressure switch
- Z Ignition transformer
- t4 Interval from flame signal to release «BV2»
- TSA Ignition safety time
- tw Waiting time for oil pre-heating
- B Time of flame establishment
- C Operating position
- D Controlled shut-down by «R»
- μC1 Microcontroller 1
- μC2 Microcontroller 2

General unit data

Mains voltage	AC 230 V +10 % / -15 % AC 120 V +10 % / -15 %
Mains frequency	50...60 Hz ±6 %
External primary fuse (Si)	6.3A (slow)
Power consumption	12 VA
Mounting orientation	optional
Weight	approx. 200 g
Degree of protection	IP40 (to be ensured through mounting)
Perm. cable lengths	max. 3m at line capacitance of 100 pF/m
Detector cable laid separately	10 m
Remote reset laid separately	20m

	LMO14 LMO44	LMO24
Terminal 1	5 A	5 A
	5 A	
Terminals 3 and 8	3 A	5 A
	5 A	
Terminals 4, 5 and 10	1 A	1 A
	1A	
Terminals 6	1 A	1 A
	2A	

Flame supervision with QRB and QRC

	QRB
QRC	
Min. detector current required (with flame)	45 µA
	70 µA
Min detector current permitted (without flame)	5.5 µA
	5.5 µA
Max. possible with flame (typically)	100 µA
	100 µA

Measurement circuit for detector current

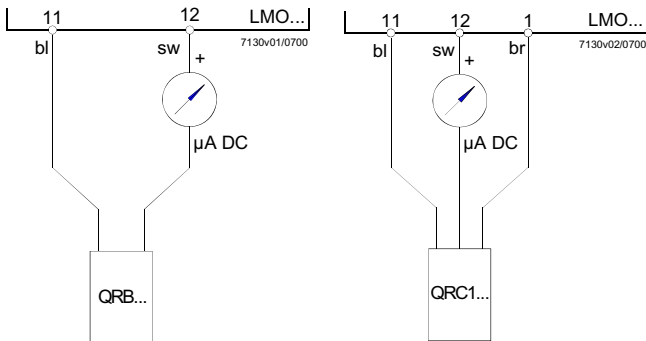

Key

µA DC	DC microamperometer with an internal resistance of 5 kW max.
bl	Blue
sw	Black
br	Brown

DELTA VM PUMPS

In the VM series of DELTA pumps the pressurised flow of oil P is shut off by a built in solenoid and may therefore be switched on for startup of the motor pre-purge) or off before the motor itself switches off (flame goes out instantly when the spray from the nozzle stops).

Oil pressure is regulated and kept constant by the piston valve which is activated when the light comes on to signify that the oil discharged exceeds nozzle capacity and is being returned to the tank (twin-pipe system) or being returned to the suction pipe through a bypass in the pipe (single-pipe system).

In this model both the single-pipe and twin-pipe versions have automatic priming. It is recommended that in either case a standard external filter be installed.

All twin-pipe models can be used as single-pipe systems with the simple removal of a nylon plug and by closing the return pipe.

Suction line vacuum	0,5 bar (15 inHg) max
Suction line pressure	0,7 bar (10 psi) max
Return line pressure	1,5 bar (21 psi) max
Cut-Off pressure	4 bar
Rotation speed	3500 RPM max
Filter	Nylon cloth 150 m, 20 cm ² Optional: Stainless steel 110m, 65 cm ²
Dimensions	Hub dia. 32 mm, shaft dia. 8 mm Optional: flange hub dia. 54 mm
Connections	Optional: 7/16" shaft Inlet - Return port: G1/4" Nozzle port : G1/8"
Weight	Pressure - Vacuum gauge: G1/8" 1100 gr

Technical data

Oil viscosity	2 ÷ 50 cSt (1,1 ÷ 6,5°E)
Oil temperature	60°C (140°F) max

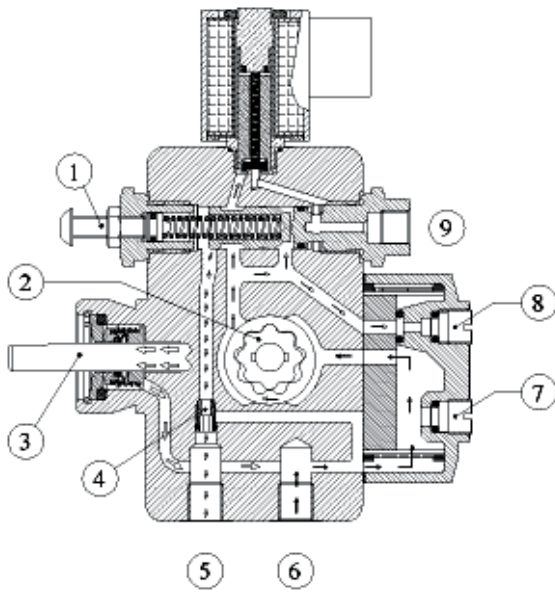

TWIN TUBE INSTALLATION

Key

- 1 Pressure regulator
- 2 Gear
- 3 Shaft seal
- 4 By-pass plug, mounted
- 5 Return
- 6 Suction
- 7 Vacuumeter gauge
- 8 Manometer gauge
- 9 Nozzle

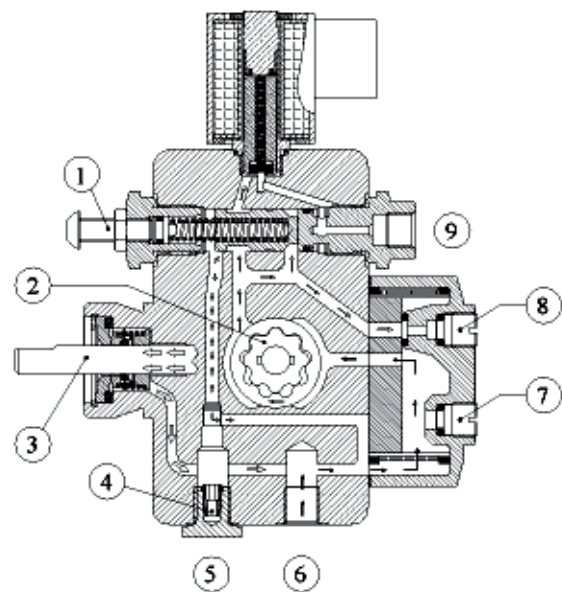

SINGLE TUBE INSTALLATION

Key

- 1 Pressure regulator
- 2 Gear
- 3 Shaft seal
- 4 By-pass plug, not inserted
- 5 Return
- 6 Suction
- 7 Vacuumeter gauge
- 8 Manometer gauge
- 9 Nozzle

SUNTEC PUMPS AS 47 - 57 - 67

Operating principle

The gear set draws oil from the tank through the built-in filter and transfers it to the valve that regulates the oil pressure to the nozzle line. All oil that does not go through the nozzle line will be dumped through the valve back to the return line in two pipe installation or, if it is a one-pipe installation, back to suction port in the gear set. In that case, the by-pass plug must be removed from the return port, and the return port sealed by steel plug and washer. The solenoid valve of the AS pump is of the "normally opened" type. When the solenoid valve is non-activated, the by-pass channel between the pressure and return sides of the valve is open. No pressure will then be built up to open the valve; it does not matter which speed the gear set has. When the solenoid is activated, this by-pass channel is closed and because of the full speed of the gear set, the pressure necessary to open the

Technical data

Mounting: flange or hub mounting according to EN 225.

Connection: threads cylindrical according to ISO 228/1.

Inlet and return G 1/4 (with facilities for conical sealing on revision 5 models)

Nozzle outlet G 1/8

Pressure gauge ports G 1/8

Vacuum gauge port G 1/8

Valve function Pressure regulation and cut-off*.

* cut-off function only assured for model pressure range.

Strainer open area 14 cm² - opening size: 150 µm.

Shaft: Ø 8 mm according to European standard EN 225.

By-pass plug inserted in return port for two-pipe system; to be removed with a 4 mm Allen key for one pipe system.

Weight 1,1- 1,5 kg (depending on the model).

Hydraulic Data

Gear size: Nozzle pressure range * Factory setting

47/57 7- 14 bar 9 bar; 67 10 - 15 bars 10 bar

* other ranges available on request, refer to the specified range of the particular fuel unit.

Operating viscosity 2 - 12 mm²/s (cSt)

Oil temperature 0 - 60°C in the pump.

Inlet pressure 2 bar max.

Return pressure 2 bar max.

Suction height: 0,45 bar max. vacuum to prevent air separation from oil.

Rated speed: 3600 rpm max. (AS 47, AS 57*) - 2850 rpm max (AS 67)

* except for AS 57 with code date before 000101 (pumps manufactured before Jan. 1st , 2000) = 2850 rpm max.

Torque (@ 45 rpm) 0,10 N.m (AS 47/57) - 0,12 N.m (AS67)

valve will be built up very rapidly, which gives a very sharp cut-on function.

Cut-off

When the burner stops, the solenoid opens the by-pass at the same moment, which drains all the oil down to the return, and the nozzle valve closes immediately. This gives a very sharp cut-off function. The cut-on and cut-off can be actuated regardless of motor speed and have an extremely fast response. When the solenoid is not activated, the torque requirement is low up to full motor speed.

Bleed

Bleeding in two pipe operation is automatic, but it may be accelerated by opening a pressure port. In one pipe operation, a pressure port must be opened to bleed the system.

Solenoid valve characteristics

Voltage	220-240 or 110-120 or 24 V; 50/60 Hz.
Consumption	9 V.A (@ voltage = 220 or 110 or 24 V).
Ambient temperature	0 - 60°C
Maximum pressure	15 bar
Certified TÜV Nr.	stamped on pump body.
Protection class	IP 41 according to IEC 529, when used with SUNTEC connector cable.

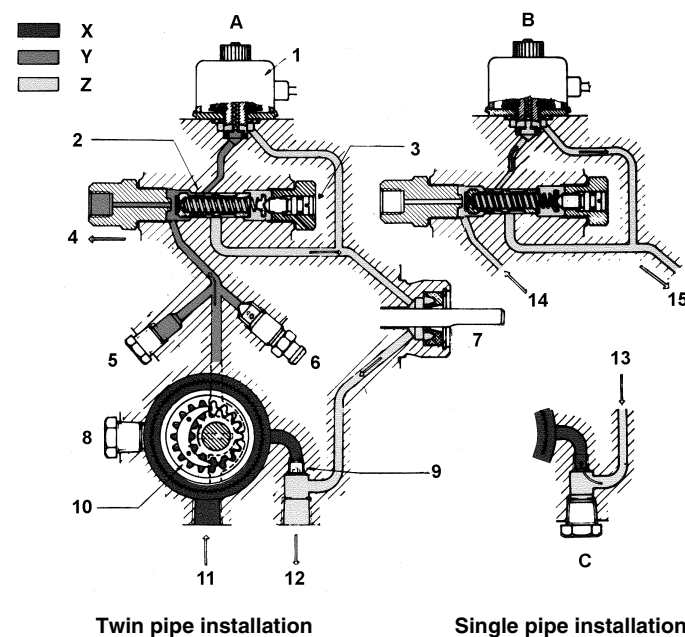

- A Closed solenoid valve
- B Open solenoid valve (NO)
- C Closed return
- 1 Solenoid valve
- 2 Pressure regulating valve
- 3 Pressure adjustment
- 4 To nozzle
- 5 Pressure gauge port
- 6 Escape valve
- 7 Shaft seal
- 8 Vacuum gauge port
- 9 By-pass plug "P"
- 10 Gear set
- 11 Inlet
- 12 Return
- 13 Back to suction
- 14 From gear set
- 15 To shaft seal and return

- X Oil under suction
- Y Oil under pressure
- Z By-passed oil returned to tank or to suction

NOTES FOR USE AND MAINTENANCE OF FUEL PUMPS

- Make sure that the by-pass plug is not used in a single pipe installation, because the fuel unit will not function properly and damage to the pump and burner motor could result.
- Do not use fuel with additives to avoid the possible formation over time of compounds which may deposit between the gear teeth, thus obstructing them.
- After filling the tank, wait before starting the burner. This will give any suspended impurities time to deposit on the bottom of the tank, thus avoiding the possibility that they might be sucked into the pump.
- On initial commissioning a "dry" operation is foreseen for a considerable length of time (for example, when there is a long suction line to bleed). To avoid damages inject some lubrication oil into the vacuum inlet.
- Care must be taken when installing the pump not to force the pump shaft along its axis or laterally to avoid excessive wear on the joint, noise and overloading the gears.
- Pipes should not contain air pockets. Rapid attachment joint should therefore be avoided and threaded or mechanical seal junctions preferred. Junction threads, elbow joints and couplings should be sealed with removable seal component. The number of junctions should be kept to a minimum as they are a possible source of leakage.
- Do not use PTFE tape on the suction and return line pipes to avoid the possibility that particles enter circulation. These could deposit on the pump filter or the nozzle, reducing efficiency. Always use O-Rings or mechanical seal (copper or aluminium gaskets) junctions if possible.
- Filter must be thoroughly cleaned at least once in a season to ensure correct working of the fuel unit. To remove the filter, unscrew the four screws on the cover. When reassemble, make sure that the filter is mounted with the feet toward the pump body. If the gasket between cover and pump housing should be damaged, it must be replaced. An external filter should always be installed in the suction line upstream of the fuel unit.

CAUTION



**Disconnect the power supply before servicing any part of the system.
Make sure the combustion chamber is free of oil or oil vapor before operating the system.**







C.I.B. UNIGAS S.p.A.

Via L.Galvani, 9 - 35011 Campodarsego (PD) - ITALY
Tel. +39 049 9200944 - Fax +39 049 9200945/9201269
web site: www.cibunigas.it - e-mail: cibunigas@cibunigas.it